



COMPLETO

Werkstattwagen / Werkstatt-Ausrüstung
Servantes / Outillage pour l'atelier
Carrelli / Assortimenti di Utensili

HIGHTECH



1
ABS-Arbeitsabdeckung mit Ablagefächern
beständig gegen Chemikalien.

*Plateau de travail ABS avec casiers,
résistant aux produits chimiques.*

Ripiano di lavoro in ABS con vani portaoggetti,
resistente ai prodotti chimici.

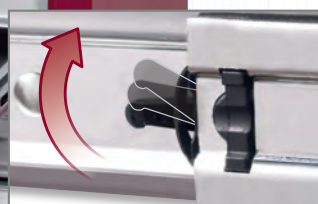

2
Einfingerbedienbare und federleichtgängige,
kugelgelagerte **Vollauszug-Schubladen**,
herausnehmbar.

*Ouverture totale facilitée du tiroir - mécanisme
à roulement - tiroir extractible.*

Cassetti estraibili, montati su guide con cusci-
netti a sfera per un preciso e morbido scorri-
mento e con **apertura totale**.

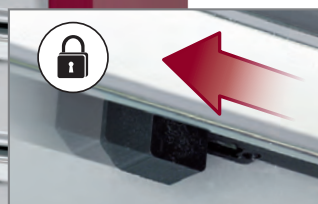

3
Einhand-Einzelschubladenverriegelung unter
der Griffblende; auch während der Fahrt bleiben
die Schubladen sicher arretiert.

*Verrouillage de chaque tiroir sous la poignée
d'ouverture; même durant le déplacement de
la servante les tiroirs restent fermés.*

Con leva di bloccaggio sui singoli cassetti;
anche durante uno spostamento i cassetti
rimangono chiusi.



4
Vielfältiges Zubehör (Seiten 9-16)
zum direkten Anbau an die stabile Doppelwand-
konstruktion der Werkstattwagen.

*Large gamme d'accessoires (pages 9-16)
pour un montage direct sur la structure très
robuste à double paroi de la servante d'atelier.*

Vasta gamma di accessori (pagine 9-16)
da fissare a lato del robusto telaio, realizzato in
doppia lamiera.



7
Kugelgelagerte Hochleistungsräder
für optimales Manövrieren. Lenkrollen
mit Rollenbremse.

*Roues sur roulement à billes haute
performance pour maniabilité optimale.
2 roues pivotantes avec freins.*

Ruote girevoli dotate di sistema frenante
e con **cuscinetti a sfera** per un'ottimale
facilità di manovra.



5
Auszugsgriffleiste mit Führung für **individuelle
Inhaltsbeschriftung**.

*Porte étiquette plexi amovible en façade du
tiroir pour indication individuelle du contenu.*

Porta etichette sul frontale del cassetto per una
indicazione individuale del contenuto.



6
Offene Schubladen können auch bei
geschlossenem Wagen in den Wagen-
körper zurückgeschoben werden.

*Système de fermeture centralisée :
même lorsque la servante est verrouillée
les tiroirs ouverts peuvent être refermés.*

Sistema di chiusura centralizzata: i cassetti
ancora aperti si possono chiudere anche
dopo quando il carrello è già stato chiuso.

Werkstattwagen
 Servante d'atelier
 Carrello porta utensili

Art.	
3907-1	6

	L1 / mm	L2 / mm	L3 / mm	kg
	650	485	943	215
A	533	414	65	25
B	533	414	110	30
C	533	414	230	30



Werkstattwagen
 Servante d'atelier
 Carrello porta utensili

Art.	
3908	8

	L1 / mm	L2 / mm	L3 / mm	kg
	650	485	943	265
A	533	414	60	25
B	533	414	110	30



Werkstattwagen
Servante d'atelier
Carrello porta utensili

Art.	
3909	11

	L1 / mm	L2 / mm	L3 / mm	⚖ kg
	650	485	970	290
A	533	414	45	20
B	533	414	70	25
C	533	414	110	30



Werkzeugkoffer zu Werkstattwagen
Coffre pour servantes
Cassettera portatile per carrelli

Art.	
3905	4

	L1 / mm	L2 / mm	L3 / mm	⚖ kg
	650	485	430	130
A	533	414	45	20
B	533	414	65	25
C	533	414	105	30



Passend zu
S'adapte sur
Compatibile con



LARGO HIGHTECH



Werkstattwagen, extra lang
 Servante d'atelier, extra longue
 Carrello porta utensili, extra largo

Art.	
3910	8

	L1 / mm	L2 / mm	L3 / mm	kg
	1015	485	970	480
A	883	414	55	50
B	883	414	105	60



Service-Werkstattwagen

mit grossem Werkzeugfach, Deckel sanft hebend und schliessend dank Gasdruckfedern, 3 kugelgelagerte Schubläden, grosses Bodenfach.

Servante spéciale d'atelier

avec grand compartiment, 3 tiroirs à roulement à ouverture et fermeture douces grâce au ralentisseur à gaz, grand compartiment inférieur.

Carrello di servizio

con tre cassetti su guide con cuscinetti a sfera, dotato di un grande scomparto a chiusura superiore tramite pistoni a gas, grande compartimento inferiore.

Art.	
3917	3

	L1 / mm	L2 / mm	L3 / mm	kg
	792	445	960	160
A	690	410	104	40
B	650	355	45	20
C	650	355	68	30
D	650	355	100	30
E	768	410		40



Werkzeugwagen

mit kugelgelagerten und einzeln verriegelbaren Vollauszug-Schubläden mit Zentralverschluss.

Servante

avec tiroirs à roulement, ouverture totale, verrouillage de chaque tiroir, fermeture centralisée.

Carrello porta utensili

con cassetti completamente estraibili dotati di guide su cuscinetti a sfera, blocco del singolo cassetto e chiusura centralizzata con serratura.

Art.	
2905	5

	L1 / mm	L2 / mm	L3 / mm	kg
	695	475	885	200
A	536	410	60	25
B	536	410	124	30
C	536	410	172	30



COMPLETO Compatible



COMPLETO Compatible

Werkzeugwagen

mit kugelgelagerten und einzeln verriegelbaren Vollauszug-Schubladen mit Zentralverschluss.

Servante

avec tiroirs à roulement, ouverture totale, verrouillage de chaque tiroir, fermeture centralisée.

Carrello porta utensili

con cassetti completamente estraibili dotati di guide su cuscinetti a sfera, blocco del singolo cassetto e chiusura centralizzata con serratura.

Art.	
2907	7

	L1 / mm	L2 / mm	L3 / mm	kg
	695	475	885	240
A	536	410	45	25
B	536	410	60	30
C	536	410	172	30



Werkzeugkoffer zu Werkzeugwagen

mit kugelgelagerten und einzeln verriegelbaren Vollauszug-Schubladen mit Zentralverschluss.

Coffre pour servantes

avec tiroirs à roulement, ouverture totale, verrouillage de chaque tiroir, fermeture centralisée.

Cassettiera portatile per carrelli

con cassetti completamente estraibili dotati di guide su cuscinetti a sfera, blocco del singolo cassetto e chiusura centralizzata con serratura.

Art.	
2904	3

	L1 / mm	L2 / mm	L3 / mm	kg
	695	475	345	115
A	536	410	60	25

COMPLETO Compatible



Passend zu
S'adapte sur
Compatible con



2905 2907

Werkzeugwagen
Servante
Carrello porta utensili

Art.	
1906	6

	L1 / mm	L2 / mm	L3 / mm	kg
	678	405	925	150
A	570	370	56	20
B	570	370	81	20
C	570	370	106	20
D	570	370	155	20



NEU
NOUVEAU
NUOVO



Werkzeugwagen
Servante
Carrello porta utensili

Art.	
1907	7

	L1 / mm	L2 / mm	L3 / mm	kg
	682	458	1000	205
A	565	395	58	25
B	565	395	138	30



Schubladen-Gummi-Antirutschmatte
Tapis caoutchouc anti-dérapant pour tiroirs
Tappetino in gomma antiscivolo per cassetti

Art.	
3918	3907-1 / 3908 / 3909

↔ L1 530 × L2 405 × L3 2 mm

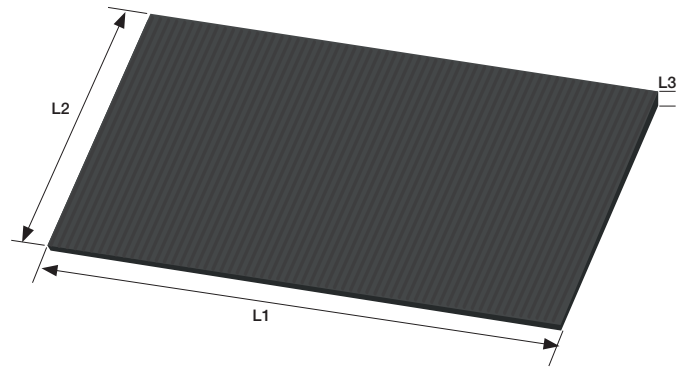

Schubladen-Unterteiler-Einsatz
aus verzinktem Stahlblech
Insert de séparation „U“ pour tiroirs
en acier zingué
Separatore ad „U“ per cassetti
in lamiera d'acciaio zincata

Art.	
3919	3907-1 / 3908 / 3909 / 3910

↔ L1 409 × L2 132 × L3 50 mm

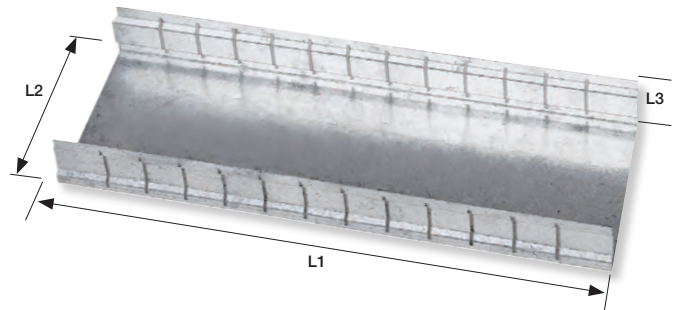

Fach-Unterteiler
zu 3919, aus verzinktem Stahlblech
Séparation
pour 3919, en acier zingué
Separatori per cassetti
per 3919, in lamiera d'acciaio zincata

Art.	
3920	3907-1 / 3908 / 3909 / 3910

↔ L1 129 × L2 50 × L3 1.2 mm

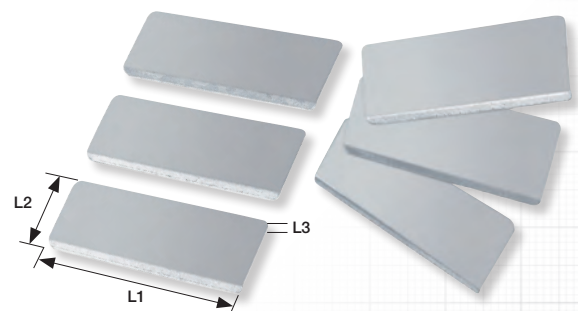

Schubladeneinlage, flach
Compartment de tiroirs plat
Vaschetta piana per cassetti

Art.	
3921	3907-1 / 3908 / 3909

↔ L1 530 × L2 200 × L3 20 mm

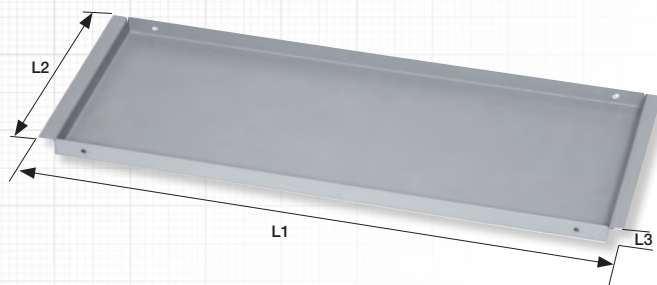

Schubladeneinlage, tief
Compartment de tiroirs profond
Vaschetta profonda per cassetti

Art.	
3922	3907-1 / 3908 / 3909

↔ L1 530 × L2 200 × L3 45 mm

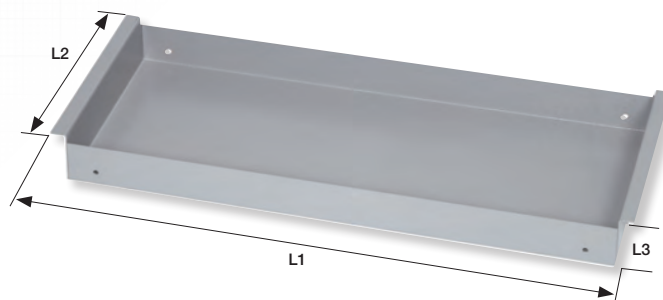

Unterteilerschale
Bac de subdivision
Divisori per cassetti

Art.	
7721	3907-1 / 3908 / 3909 / 3910 / 2905 / 2907 / 1907

↔ L1 165 × L2 195 × L3 35 mm

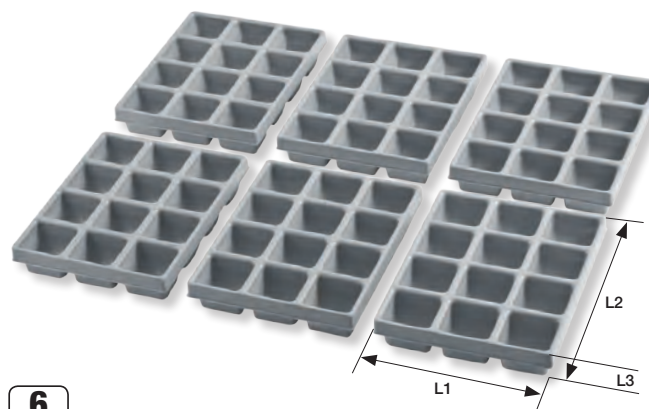

6
PCS

Unterteilerschale
Bac de subdivision
 Divisori per cassette

Art.	
7722	3907-1 / 3908 / 3909 / 3910 / 2905 / 2907 / 1907

↔ L1 165 × L2 195 × L3 35 mm

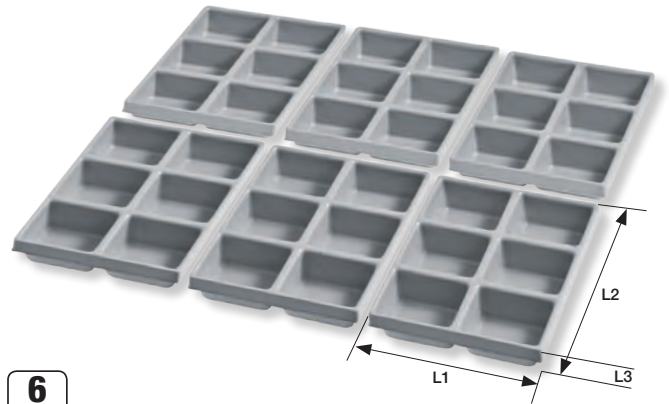

6
PCS

Unterteilerschale
Bac de subdivision
 Divisori per cassette

Art.	
7723	3907-1 / 3908 / 3909 / 3910 / 2905 / 2907 / 1907

↔ L1 165 × L2 195 × L3 35 mm

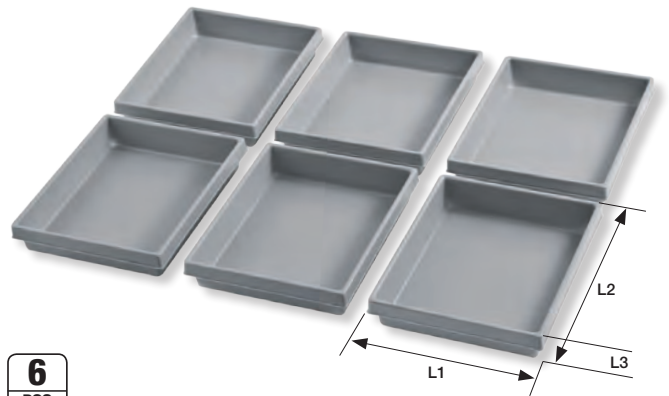

6
PCS

Unterteilerschale
Bac de subdivision
 Divisori per cassette

Art.	
7724	3907-1 / 3908 / 3909 / 3910 / 2905 / 2907 / 1907

↔ L1 160 × L2 390 × L3 35 mm

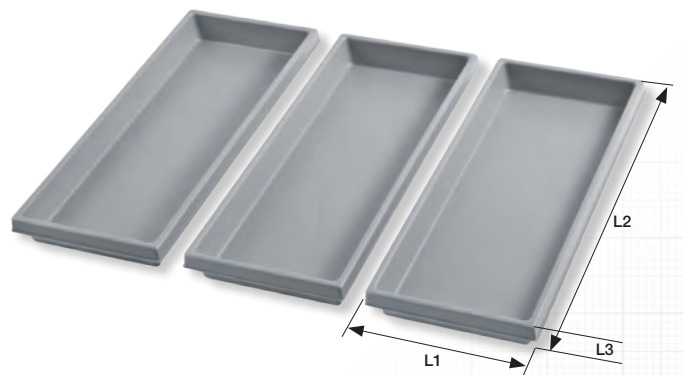

3
PCS

Unterteilerschalen-Satz
Jeu de bacs de subdivision
Set di divisori per cassetti

Art.	
7725	3907-1 / 3908 / 3909 / 3910 / 2905 / 2907 / 1907



5
PCS

Aussenkorb
mit Einlegewanne
Corbeille extérieure
avec bac

Cestino esterno
con salvagoccia

Art.	
3923	3907-1 / 3908 / 3909 / 3910

↔ L1 280 × L2 115 × L3 95 mm

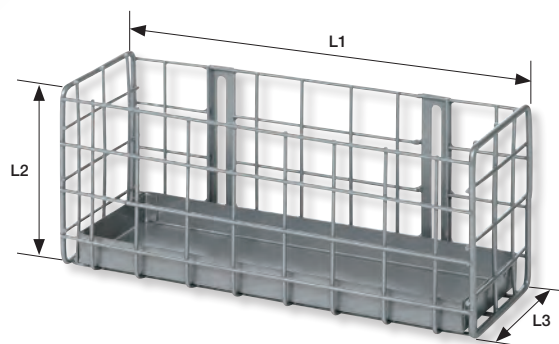

Universalkorb
mit Halter

Dévidoir
avec support

Cestino universale
dotato di ganci

Art.	
3924	3907-1 / 3908 / 3909 / 3910

↔ L1 365 × L2 220 × L3 215 mm

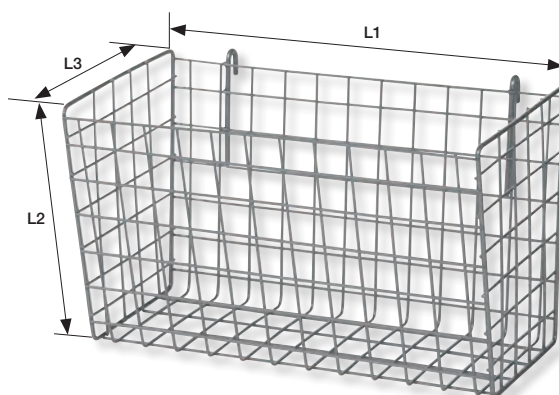
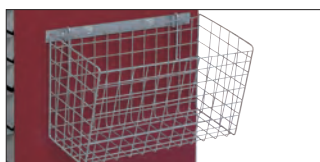

Halterung für Reinigungstuch-Rollen Support de rouleau d'essuyage Supporto portarotolo

Art.	
3925	3907-1 / 3908 / 3909 / 3910

↔ L1 330 × L2 175 × L3 140 mm

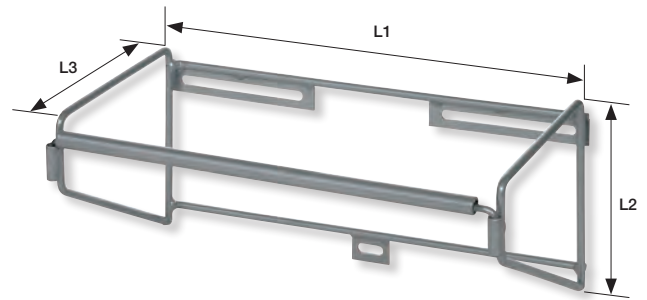

Seitentisch

mit integriertem Rollenhalter für den Gebrauch eines Notebooks oder als zusätzliche Abstellfläche.

Table latérale

avec porte-rouleau intégré facilitant l'usage d'un ordinateur ou permettant tout simplement de bénéficier d'un espace de travail supplémentaire.

Tavolino laterale

con portarotolo integrato per l'utilizzo di notebook o semplicemente come spazio di lavoro aggiuntivo.

Art.	
3927	3907-1 / 3908 / 3909 / 3910

↔ L1 385 × L2 380 × L3 375 mm



Seitentisch zu KWR-Werkstattwagen

zum Gebrauch eines Notebooks oder für Dokumentenablage.

Table latérale pour servante KWR

permettant l'usage d'un ordinateur ou le dépôt de documents.

Tavolinetto laterale per carrelli KWR

che permette l'utilizzo di notebook o semplicemente come ripiano d'appoggio.

Art. 

1927

2905 / 2907

↔ L1 280 × L2 210 mm



Magnetteller

rostfrei

Coupelle magnétique

en inox

Vassoio magnetico

in inox

Art. 

2950

1200 g

↔ Ø 150 × 40 mm



Magnetteller

rostfrei

Coupelle magnétique

en inox

Vassoio magnetico

in inox

Art. 

2951

2 × 1200 g

↔ 240 × 140 × 40 mm



Magnetschale

rostfrei, speziell gross, mit 4 starken, gummigeschützten Dauermagneten.

Coupelle magnétique

en inox, grand format, avec 4 aimants puissants, revêtus de matière en caoutchouc.

Vassoio magnetico

in acciaio inox con 4 potenti magneti rivestiti in gomma.

Art.

2952

2 x  0 g

↕ 290 × 270 × 29 mm



Magnetischer Werkzeughalter

für Stecknüsse und Druckluftwerkzeuge

Support magnétique

pour douilles et outils pneumatiques

Supporto magnetico

per bussole ed utensili pneumatici

Art.

3929

↕ L 400 mm



Holz-Arbeitsplatte

zu Werkstattwagen 3910

Plateau en bois

pour servante 3910

Piano di lavoro in legno

per carrello 3910

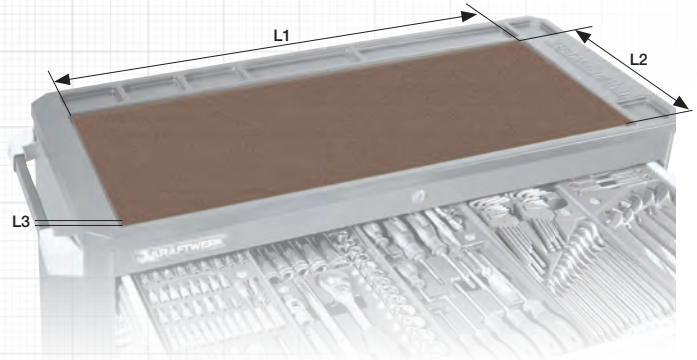

Art.

3926

↔ L1 864 × L2 367 × L3 9 mm

Werkstattwagen-Schutzdecke

Couverture de protection pour servantes

Telo protezione per carrello

NEU
NOUVEAU
NUOVO

Art.



3930

3907-1 / 3908 / 3909 / 2905 / 2907 /
1906 / 1907

↔ 73 × 55 × 89 mm



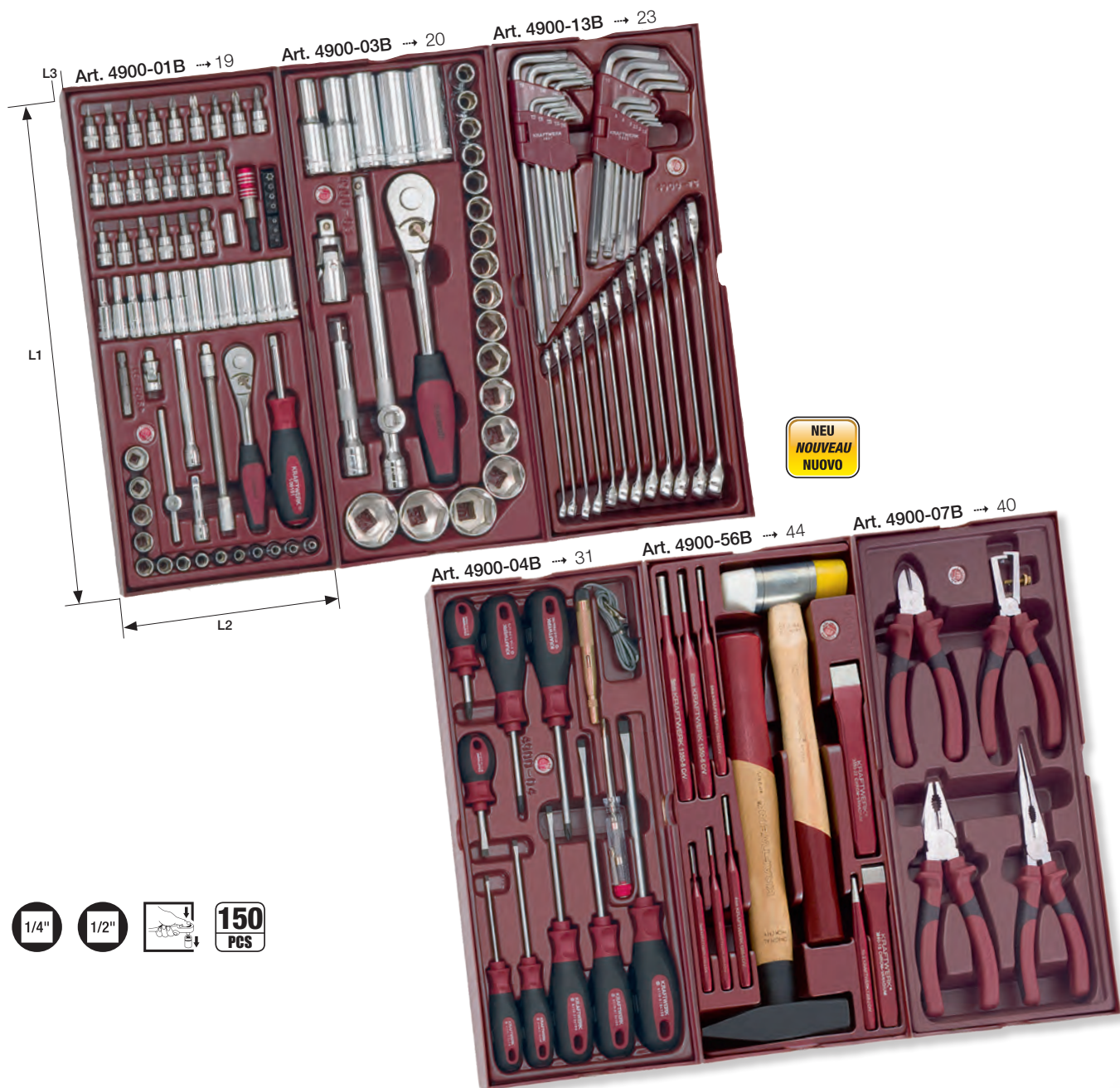

Werkzeug-Zusammenstellung

Basis-Sortiment für 2 Schubladen

Assortiment d'outils

de base pour 2 tiroirs

Assortimento di utensili

base per 2 cassetti

Art.	
4909	4900-01B, 4900-03B, 4900-13B, 4900-04B, 4900-56B, 4900-07B

↔ L1 402 × L2 173 × L3 48 mm

Werkzeug-Zusammenstellung

mit Werkstattwagen

Assortiment d'outils

avec servantes

Assortimento di utensili

con carrelli

	Art.	
1	3907-4909	3
2	3908-4909	3
3	3909-4909	4
4	3905-4909	4
5	2905-4909	6
6	2907-4909	7
7	2904-4909	7





Werkzeug-Zusammenstellung

Basis-Sortiment für 3 Schubladen

Assortiment d'outils

de base pour 3 tiroirs

Assortimento di utensili

base per 3 cassetti

Art.	
4911	4900-01B, 4900-03B, 4900-04B, 4900-13B, 4900-14B, 4900-07B, 4900-56B, 4900-10B, 4900-11B

↔ L1 402 × L2 173 × L3 48 mm

Werkzeug-Zusammenstellung

mit Werkstattwagen

Assortiment d'outils

avec servantes

Assortimento di utensili

con carrelli

	Art.	
1	3907-4911	3
2	3908-4911	3
3	3909-4911	4
4	3905-4911	4
5	2905-4911	6
6	2907-4911	7
7	2904-4911	7





Steckschlüssel-Schale
Coquille de douilles
 Assortimento di chiavi a bussola in vaschetta



Art.

4900-01B

↔ L1 402 × L2 173 × L3 48 mm

- | | | | | | |
|--|----|---|--|---|-----------------------------|
| | 15 | 3.5-4-4.5-5-5.5-6-7-8-9-10-11-12-13-14 mm | | 2 | 50 mm / 100 mm |
| | 12 | 4-4.5-5-5.5-6-7-8-9-10-11-12-13 mm | | | 150 mm |
| | 3 | 4-5-5.5-6 mm | | | 115 mm |
| | 3 | PH 1-2-3 | | | 1/4" 1/4" |
| | 3 | PZ 1-2-3 | | 7 | T10-T15-T20-T25-T27-T30-T40 |
| | 8 | T8-T10-T15-T20-T25-T27-T30-T40 | | | 1/4" 1/4" |
| | 6 | 3-4-5-6-7-8 mm | | | 1/4" 1/4" |
| | | 1/4" 1/4" | | | |
| | | 1/4" 1/4" | | | |
- Art. 3200



Steckschlüssel-Schale
Coquille de douilles
 Assortimento di chiavi a bussola in vaschetta



Art.

4900-02B

↔ L1 402 × L2 173 × L3 48 mm

- | | | |
|--|----|---|
| | 15 | 8-9-10-11-12-13-14-15-16-17-18-19-21-22-24 mm |
| | 8 | 10-11-12-13-14-15-17-19 mm |
| | 3 | 16 mm / 18 mm / 21 mm |
| | | 3/8" 3/8" |
| | 2 | 75 mm / 250 mm |
| | | 1/2" 3/8" |
| | | 3/8" 1/4" |
| | | 1/4" 3/8" |

Art. 3210

1/2"



27
PCS

Steckschlüssel-Schale
Coquille de douilles
Assortimento di chiavi a bussola in vaschetta



Art.

4900-03B

↕ L1 402 × L2 173 × L3 48 mm

17 10-11-12-13-14-15-16-17-18
19-21-22-24-27-30-32-34 mm

5 10-13-17-19-22 mm

1/2" 1/2"

2 125 mm / 250 mm

3/8" 1/2"

Art. 3220

1/4"

3/8"



50
PCS

inch

Steckschlüssel-Schale
Zollmasse
Coquille de douilles en pouce
Assortimento di chiavi a bussola in pollici in vaschetta



Art.

4900-29B

↕ L1 402 × L2 173 × L3 48 mm

9 3/16"-7/32"-1/4"-9/32"-5/16"
11/32"-3/8"-7/16"-1/2"

9 3/16"-7/32"-1/4"-9/32"-5/16"
11/32"-3/8"-7/16"-1/2"

1/4" 1/4"

2 50 mm / 100 mm

3/8" 1/4"

Art. 4009 **EXTREME**

8 9/16"-5/8"-11/16"-3/4"
13/16"-7/8"-15/16"-1"

3 9/16"-11/16"-3/4"

2 5/8"-13/16"

3/8" 3/8"

2 75 mm / 250 mm

1/2" 3/8"

Art. 4019 **EXTREME**

9 1/16"-5/64"-3/32"-1/8"-5/32"
3/16"-1/4"-5/16"-3/8"

1/2" S2 quality 33 PCS

Bit-Stecknuss-Schale
Coquille de douilles-embouts
 Assortimento di bussole giravite lunghe e corte in vaschetta



Art.

4900-38B

↕ L1 402 × L2 173 × L3 48 mm

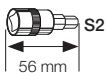

- 6 ⚙ T30-T40-T45-T50-T55-T60
- 6 ⚙ 5-6-7-8-10-12 mm
- 6 ⚙ M5-M6-M8-M10-M12-M14

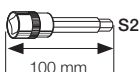

- 5 ⚙ T30-T40-T45-T50-T55
- 5 ⚙ 6-7-8-10-12 mm
- 5 ⚙ M5-M6-M8-M10-M12

1/2" 5/16" S2 quality 49 PCS

NEU
NOUVEAU
NUOVO

Spezial-Bit-Stecknuss-Schale
Coquille de douilles-embouts spéciales
 Assortimento di bussole giravite speciale in vaschetta



Art.

4900-58B

↕ L1 402 × L2 173 × L3 48 mm

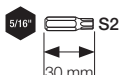

- 9 ⚙ T20-T25-T27-T30-T40
T45-T50-T55-T60
- 7 ⚙ 4-5-6-7-8-10-12 mm
- 5 ⚙ M5-M6-M8-M10-M12



- 3 ⚙ T30-T40-T45



- 9 ⚙ T20-T25-T27-T30-T40
T45-T50-T55-T60
- 7 ⚙ 4-5-6-7-8-10-12 mm
- 5 ⚙ M5-M6-M8-M10-M12

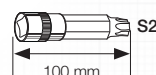

- ⚙ T70

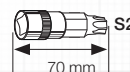

- ⚙ T80



- ⊙ 3/8" ⊙ 5/16"

- ⊙ 1/2" ⊙ 5/16"

38
PCS

Durchsteck-Steckschlüssel-
Schale

Coquille de douilles
débouchées

Assortimento chiavi a bussola
in serie forate in vaschetta

Art.

4900-49B

↔ L1 402 × L2 173 × L3 48 mm



GEARRATCHET

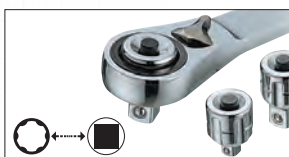

- | | | |
|----|-------|----------------------------------|
| 9 | 13 mm | 3.5-4-4.5-5-5.5-6-7-8-9 mm |
| 10 | 20 mm | 10-11-12-13-14-15-16-17-18-19 mm |
| 8 | 30 mm | 20-21-22-24-27-30-32-34 mm |



13 mm × 1/4"

20 mm × 3/8"

30 mm × 1/2"



- | | | |
|---|-------|----------------|
| 1 | 13 mm | 75 mm |
| 1 | 20 mm | 75 mm |
| 2 | 30 mm | 75 mm / 155 mm |



13 mm × 1/4"



13 mm Art. 590000

20 mm Art. 600000

30 mm Art. 610000

1/4"

3/8"

1/2"

5/16"

CrMo

71
PCS

Spezial-Steckschlüssel-/
Bit-Schale

Coquille de douilles
et embouts spéciaux

Assortimento di chiavi a bussola
a macchina e inserti in vaschetta

Art.

4900-20B

↔ L1 402 × L2 173 × L3 48 mm



- | | |
|----|------------------------------------|
| 6 | E4-E6-E7-E8-E10-E11 |
| 7 | E10-E11-E12-E14-E16-E18-E20 |
| 5 | E16-E18-E20-E22-E24 |
| 11 | 9-10-11-13-14-17-19-21-22-23-24 mm |
| 5 | 17-19-21-22-24 mm |

3/8" 5/16"

1/2" 5/16"



3 8-10-12 mm

2 PH 3-4

2 PZ 3-4

6 T40-T45-T47-T50-T55-T60

12 T10-T15-T20-T25-T27-T30
T40-T45-T50-T55-T60-T70

5 6-8-10-12-14 mm

4 M6-M8-M10-M12

CrMo



31
PCS

Gabelring-/Inbus-/TX-Winkelstiftschlüssel-Schale

Coquille de clés combinées et de clés mâles hexagonales et TX

Assortimento di chiavi combinate, maschi esagonali e TX in vaschetta



Art.

4900-13B

↔ L1 402 × L2 173 × L3 48 mm

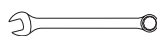

DIN 3113

Art. 3508	8 mm	Art. 3514	14 mm
Art. 3509	9 mm	Art. 3515	15 mm
Art. 3510	10 mm	Art. 3516	16 mm
Art. 3511	11 mm	Art. 3517	17 mm
Art. 3512	12 mm	Art. 3518	18 mm
Art. 3513	13 mm	Art. 3519	19 mm



DIN 2936 S2



● ● Art. 3602

1.5-2-2.5-3-4-5-6-7-8-10 mm

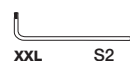

XXL S2

★ ★ Art. 3607

T10-T15-T20-T25-T27
T30-T40-T45-T50

8
PCS

Gabelringschlüssel-Schale

Coquille de clés combinées

Assortimento di chiavi combinate in vaschetta



Art.

4900-14B

↔ L1 402 × L2 173 × L3 48 mm

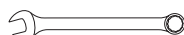

DIN 3113

Art. 3505	5.5 mm
Art. 3506	6 mm
Art. 3507	7 mm
Art. 3520	20 mm
Art. 3521	21 mm
Art. 3522	22 mm
Art. 3523	23 mm
Art. 3524	24 mm

15
PCS



inch

Gabelringschlüssel-Schale
Zollmasse

Coquille de clés
combinées en pouce

Assortimento di chiavi com-
binate in pollici in vaschetta

Art.

4900-30B

↔ L1 402 × L2 173 × L3 48 mm



COMBINATION
CLICKCRAFT

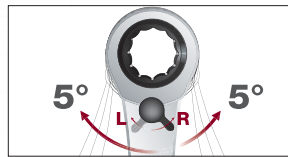
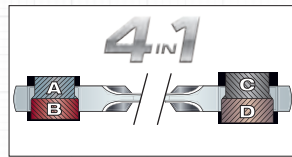

A 5/16" **B** 3/8"
Art. 3404-51612

C 7/16" **D** 1/2"

Art. 3587 1/4" Art. 3594 11/16"

Art. 3588 5/16" Art. 3595 3/4"

Art. 3589 3/8" Art. 3596 13/16"

Art. 3590 7/16" Art. 3597 7/8"

Art. 3591 1/2" Art. 3598 15/16"

Art. 3592 9/16" Art. 3599 1"

Art. 3593 5/8"

A 9/16" **C** 11/16"
B 5/8" Art. 3404-91634 **D** 3/4"



19
PCS



Ratschen-Ring-
gabelschlüssel-Schale

Coquille de clés
combinées à cliquet

Assortimento di chiavi com-
binate a cricchetto in vaschetta

Art.

4900-17B

↔ L1 402 × L2 173 × L3 48 mm



COMBINATION
CLICKCRAFT

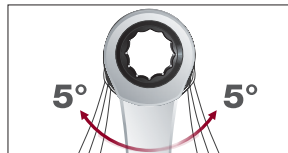

Art. 3405 5.5 mm
Art. 3406 6 mm
Art. 3407 7 mm
Art. 3408 8 mm
Art. 3409 9 mm
Art. 3410 10 mm
Art. 3411 11 mm
Art. 3412 12 mm
Art. 3413 13 mm

Art. 3414 14 mm
Art. 3415 15 mm
Art. 3416 16 mm
Art. 3417 17 mm
Art. 3418 18 mm
Art. 3419 19 mm

Art. 3691 1/4" 10 mm
Art. 3692 3/8" 13 mm
Art. 3693 1/2" 19 mm

Art. 2694 1/4" 10 mm



COMPLETO Serie 4900

COMBINATION *plus*
DOUBLE RATCHET
CLICKCRAFT



Doppel-Ratschen-Ring-
gabelschlüssel-Schale
*Coquille de clés
combinées à cliquet double*
Assortimento di chiavi
combinate a doppio
cricchetto in vaschetta



Art.

4900-40B

↕ L1 402 × L2 173 × L3 48 mm

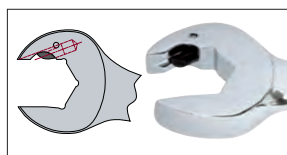
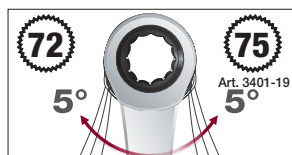

Art. 3405	5.5 mm
Art. 3406	6 mm
Art. 3407	7 mm

Art. 3401-08	8 mm
Art. 3401-09	9 mm
Art. 3401-10	10 mm
Art. 3401-11	11 mm
Art. 3401-12	12 mm
Art. 3401-13	13 mm
Art. 3401-14	14 mm
Art. 3401-15	15 mm
Art. 3401-16	16 mm
Art. 3401-17	17 mm
Art. 3401-18	18 mm
Art. 3401-19	19 mm

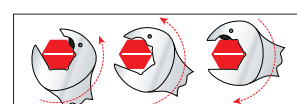

Option / Option / Opzionali

Art. 3691	1/4"	10 mm
Art. 3692	3/8"	13 mm
Art. 3693	1/2"	19 mm
Art. 2694	1/4"	10 mm



Video
KRAFTWERKtools.com/video/double-ratchet



90° Ratschen-Ringgabel-
schlüssel-Schale, extra lang
*Coquille de clés combinées
à cliquet 90°, extra longues*
Assortimento di chiavi
combinate a cricchetto 90°,
extra lunghi in vaschetta



LARGO 90
CLICKCRAFT

Art.

4900-28B

↕ L1 402 × L2 173 × L3 48 mm

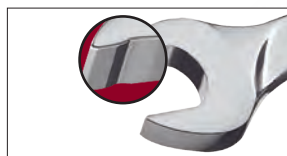
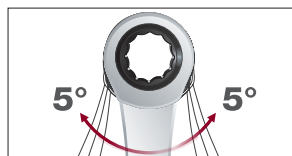

Art. 4405-08	8 mm
Art. 4405-09	9 mm
Art. 4405-10	10 mm
Art. 4405-11	11 mm
Art. 4405-12	12 mm
Art. 4405-13	13 mm

Art. 4405-14	14 mm
Art. 4405-15	15 mm
Art. 4405-16	16 mm
Art. 4405-17	17 mm
Art. 4405-18	18 mm
Art. 4405-19	19 mm

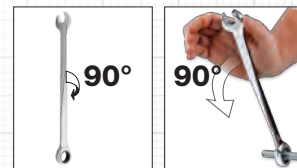

14
PCS



Umschaltbare Ratschen-Ringgabelschlüssel-Schale
Coquille de clés combinées à cliquet réversible

Assortimento di chiavi combinate a cricchetto reversibili in vaschetta

Art.

4900-47B

↕ L1 402 × L2 173 × L3 48 mm



REVERSIBLE
CLICKCRAFT

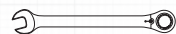
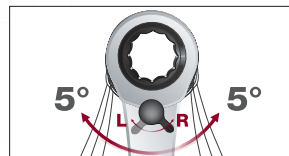

Art. 3404-08	8 mm	Art. 3404-15	15 mm
Art. 3404-09	9 mm	Art. 3404-16	16 mm
Art. 3404-10	10 mm	Art. 3404-17	17 mm
Art. 3404-11	11 mm	Art. 3404-18	18 mm
Art. 3404-12	12 mm	Art. 3404-19	19 mm
Art. 3404-13	13 mm	Art. 3404-22	22 mm
Art. 3404-14	14 mm	Art. 3404-24	24 mm

14
PCS



Flexible Ratschen-Ringgabelschlüssel-Schale
Coquille de clés combinées à cliquet articulées

Assortimento di chiavi a cricchetto snodate in vaschetta

Art.

4900-46B

↕ L1 402 × L2 173 × L3 48 mm



FLEX
CLICKCRAFT

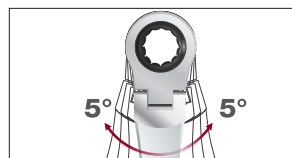

Art. 3403-08	8 mm	Art. 3403-15	15 mm
Art. 3403-09	9 mm	Art. 3403-16	16 mm
Art. 3403-10	10 mm	Art. 3403-17	17 mm
Art. 3403-11	11 mm	Art. 3403-18	18 mm
Art. 3403-12	12 mm	Art. 3403-19	19 mm
Art. 3403-13	13 mm	Art. 3403-22	22 mm
Art. 3403-14	14 mm	Art. 3403-24	24 mm



Winkel-Ratschen-Ring-
gabelschlüssel-Schale
*Coquille de clés combinées
à cliquet à angle*

Assortimento di chiavi
combinata a cricchetto
orientabili in vaschetta



Art.

4900-41B

↕ L1 402 × L2 173 × L3 48 mm

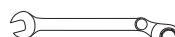
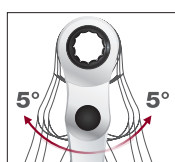

Art. 3402-08	8 mm
Art. 3402-09	9 mm
Art. 3402-10	10 mm
Art. 3402-11	11 mm
Art. 3402-12	12 mm
Art. 3402-13	13 mm

Art. 3402-14	14 mm
Art. 3402-15	15 mm
Art. 3402-16	16 mm
Art. 3402-17	17 mm
Art. 3402-18	18 mm
Art. 3402-19	19 mm

Option / Option / Opzionali

	Art. 3691	● 1/4"	■ 10 mm
	Art. 3692	● 3/8"	■ 13 mm
	Art. 3693	● 1/2"	■ 19 mm
	Art. 2694	● 1/4"	○ 10 mm



Doppelgabelschlüssel-Schale
Coquille de clés à fourche
Assortimento di chiavi fisse a
forchetta in vaschetta



Art.

4900-16B

↕ L1 402 × L2 173 × L3 48 mm

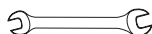

DIN 3110

Art. 3560	6 × 7 mm	Art. 3565	16 × 17 mm
Art. 3561	8 × 9 mm	Art. 3566	18 × 19 mm
Art. 3562	10 × 11 mm	Art. 3567	21 × 22 mm
Art. 3563	12 × 13 mm	Art. 3568	24 × 27 mm
Art. 3564	14 × 15 mm	Art. 3569	30 × 32 mm

11
PCS

Doppelringschlüssel-Schale
Coquille de clés polygonales
Assortimento di chiavi poligo-
nali doppie in vaschetta

Art.

4900-15B

↕ L1 402 × L2 173 × L3 48 mm

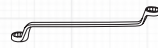

DIN 838

Art. 3480	6 × 7 mm	Art. 3486	18 × 19 mm
Art. 3481	8 × 9 mm	Art. 3487	20 × 22 mm
Art. 3482	10 × 11 mm	Art. 3488	21 × 23 mm
Art. 3483	12 × 13 mm	Art. 3489	24 × 27 mm
Art. 3484	14 × 15 mm	Art. 3491	30 × 32 mm
Art. 3485	16 × 17 mm		

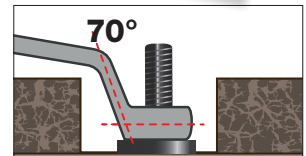

13
PCS



Offener Bremsschlüssel/
Flexible Stubby-Ratschen-
Ringgabelschlüssel-Schale
*Coquille de clés à tuyauter/
clés combinées à cliquet
articulées extra courtes*
Assortimento di chiavi per
raccordi tubi e chiavi
combinati a cricchetto
snodate corte in vaschetta

Art.

4900-22B

↕ L1 402 × L2 173 × L3 48 mm

NEU
NOUVEAU
NUOVO



STUBBY FLEX
CLICKRAFT

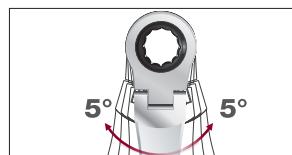

180°

Art. 3403-08S	8 mm	Art. 3580-00	9 × 11 mm
Art. 3403-10S	10 mm	Art. 3580-01	10 × 12 mm
Art. 3403-11S	11 mm	Art. 3580-02	13 × 14 mm
Art. 3403-12S	12 mm	Art. 3580-03	15 × 17 mm
Art. 3403-13S	13 mm	Art. 3580-04	3/8" × 7/16"
Art. 3403-14S	14 mm	Art. 3580-05	1/2" × 9/16"
		Art. 3580-06	5/8" × 11/16"

13
PCS

Pfeifenkopfschlüssel-Schale Coquille de clés à pipe débouchées

Assortimento di chiavi a pipa in vaschetta



Art.	
4900-18B	
4900-48B	

↔ L1 402 × L2 173 × L3 48 mm

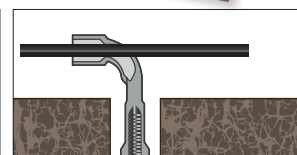
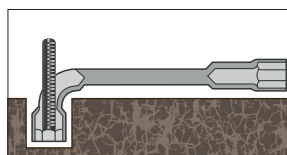

4900-18B

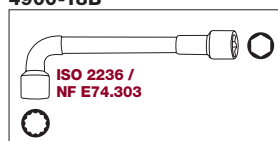

Art. 2598-08	8 mm
Art. 2598-09	9 mm
Art. 2598-10	10 mm
Art. 2598-11	11 mm
Art. 2598-12	12 mm
Art. 2598-13	13 mm
Art. 2598-14	14 mm

Art. 2598-15	15 mm
Art. 2598-16	16 mm
Art. 2598-17	17 mm
Art. 2598-18	18 mm
Art. 2598-19	19 mm
Art. 2598-22	22 mm

4900-48B

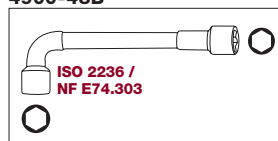

Art. 2597-08	8 mm
Art. 2597-09	9 mm
Art. 2597-10	10 mm
Art. 2597-11	11 mm
Art. 2597-12	12 mm
Art. 2597-13	13 mm
Art. 2597-14	14 mm

Art. 2597-15	15 mm
Art. 2597-16	16 mm
Art. 2597-17	17 mm
Art. 2597-18	18 mm
Art. 2597-19	19 mm
Art. 2597-22	22 mm

14
PCS

Rohrsteckschlüssel-Schale Coquille de clés en tube droites

Assortimento di chiavi a tubo in vaschetta



Art.
4900-23B

↔ L1 402 × L2 173 × L3 48 mm

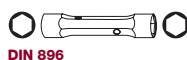

Art. 2599-0607	6 × 7 mm
Art. 2599-0809	8 × 9 mm
Art. 2599-1011	10 × 11 mm
Art. 2599-1213	12 × 13 mm
Art. 2599-1415	14 × 15 mm
Art. 2599-1617	16 × 17 mm

Art. 2599-1819	18 × 19 mm
Art. 2599-2022	20 × 22 mm
Art. 2599-2123	21 × 23 mm
Art. 2599-2427	24 × 27 mm
Art. 2599-2528	25 × 28 mm
Art. 2599-3032	30 × 32 mm

Art. 2599-1012	210 mm
Art. 2599-3457	165 mm

9
PCS

Doppelgelenkschlüssel-Schale
Coquille de clés
double-articulées
Assortimento di chiavi doppie
a bussola in vaschetta

Art.

4900-27B

↔ L1 402 × L2 173 × L3 48 mm

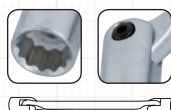

- Art. 2590-0809 8 × 9 mm
- Art. 2590-1011 10 × 11 mm
- Art. 2590-1213 12 × 13 mm
- Art. 2590-1415 14 × 15 mm
- Art. 2590-1617 16 × 17 mm
- Art. 2590-1819 18 × 19 mm

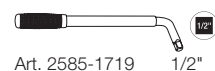
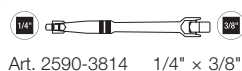
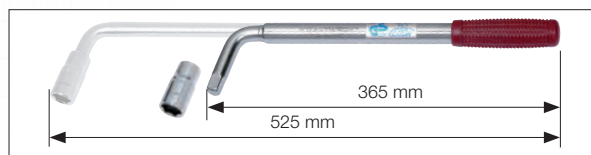

13
PCS

Schraubendreher-Schale
VSM Swiss Norm
Coquille de tournevis
VSM norme Suisse
Assortimento di giraviti VSM
norma svizzera in vaschetta

Art.

4900-50B

↔ L1 402 × L2 173 × L3 48 mm



- Art. 2100-0 0.4 × 2.5 mm
- Art. 2100-1 0.5 × 3.5 mm
- Art. 2100-2 0.6 × 4 mm
- Art. 2100-3 0.8 × 5.5 mm
- Art. 2100-4 1.0 × 6.5 mm
- Art. 2100-5 1.2 × 8 mm
- Art. 2100-6 1.6 × 10 mm

- Art. 2190-1 PH1
- Art. 2190-2 PH2
- Art. 2190-3 PH3

- Art. 2192-1 PZ1
- Art. 2192-2 PZ2

- 100-250 V
- Art. 2138

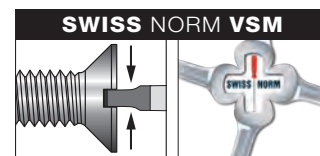



NEU
NOUVEAU
NUOVO



Schraubendreher-Schale
PB Swissgrip
Coquille de tournevis
PB Swissgrip
Assortimento di giraviti
PB Swissgrip in vaschetta

Art.

4900-60B

↔ L1 402 × L2 173 × L3 48 mm

	Art. PB8100.5	1.2 × 8 mm
	Art. PB8100.4-140	1.0 × 6.5 mm
	Art. PB8100.3-120	0.8 × 5.5 mm
	Art. PB8100.2-100	0.6 × 4.0 mm
	Art. PB8100.1-90	0.5 × 3.5 mm
	Art. PB8190	PH1 × 80
	Art. PB8190	PH2 × 100/6
	Art. PB8451	10 × 30 mm
	Art. PB175.0-50	110-250 V

PB SWISS TOOLS



1/4" S2 T10-T15-T20-T25-T27-T30-T40



Schraubendreher-Schale
Coquille de tournevis
Assortimento di giraviti
in vaschetta

Art.

4900-04B

↔ L1 402 × L2 173 × L3 48 mm

	Art. 4110-1	0.6 × 3 mm		Art. 4112-2	1.1 × 6 mm
	Art. 4110-2	0.8 × 4 mm		Art. 4117-2	PH 2
	Art. 4110-3	1.0 × 5 mm		Art. 2138	100-250 V
	Art. 4110-4	1.1 × 6 mm		Art. 2139	12 V
	Art. 4110-5	1.2 × 8 mm			
	Art. 4115-1	PH 1			
	Art. 4115-2	PH 2			

ergokraft



S2 quality **14** PCS

Schraubendreher-Schale
Coquille de tournevis
Assortimento di giraviti
in vaschetta

Art.
4900-05B

↔ L1 402 × L2 173 × L3 48 mm



ergokraft

- | | |
|--|-------------------|
| | ★ Art. 4125-08 T8 |
| | Art. 4125-10 T10 |
| | Art. 4125-15 T15 |
| | Art. 4125-20 T20 |
| | Art. 4125-25 T25 |
| | Art. 4125-27 T27 |
| | Art. 4125-30 T30 |
| | Art. 4125-40 T40 |

- | | |
|--|----------------------------|
| | Art. 3177-20 0.45 × 2.0 mm |
| | Art. 3177-24 0.5 × 2.4 mm |
| | Art. 3177-30 0.6 × 3.0 mm |
| | Art. 3177-35 0.65 × 3.5 mm |

- | | | |
|--|---|------------------|
| | + | Art. 3177-0 PH 0 |
| | | Art. 3177-1 PH 1 |

S2 quality **8** PCS

Schlagkappen-Schraubendreher-Schale
Coquille de tournevis de frappe
Assortimento di giraviti a battere
in vaschetta

Art.
4900-54B

↔ L1 402 × L2 173 × L3 48 mm

NEU
NOUVEAU
NUOVO



ergokraft



- | | | |
|--|---------------------------|---------|
| | Art. 4140-3 5.5 × 100 mm | 5.5 mm |
| | Art. 4140-4 6.5 × 125 mm | 6.5 mm |
| | Art. 4140-5 8.0 × 150 mm | 8.0 mm |
| | Art. 4140-6 10.0 × 175 mm | 10.0 mm |
| | + | |
| | Art. 4145-1 PH1 × 75 mm | 5.0 mm |
| | Art. 4145-2 PH2 × 100 mm | 6.0 mm |
| | + | |
| | Art. 4150-1 PZ1 × 75 mm | 5.0 mm |
| | Art. 4150-2 PZ2 × 100 mm | 6.0 mm |

DIN 5260-PH
ISO 8764-PH

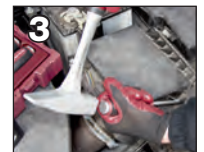

COMPLETO Serie 4900 ergokraft

S2
quality

8
PCS

Steckschlüssel mit
Griff-Schale

*Coquille de clés à douille
emmanchée*

Assortimento di giraviti
a bussola in vaschetta



Art.

4900-31B

↔ L1 402 × L2 173 × L3 48 mm

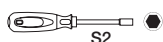

S2

Art. 4127-055	5.5 mm
Art. 4127-06	6 mm
Art. 4127-07	7 mm
Art. 4127-08	8 mm
Art. 4127-10	10 mm
Art. 4127-11	11 mm
Art. 4127-12	12 mm
Art. 4127-13	13 mm

S2
quality

7
PCS

Kugelkopf-T-Griff-
Schraubendreher-Schale

*Coquille de tournevis
mâles à tête sphérique en T*

Assortimento di chiavi
esagonali a T in vaschetta
con testa scorrevole



ergokraft

Art.

4900-25B

↔ L1 402 × L2 173 × L3 48 mm

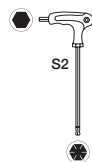

S2

Art. 3636-3	3 mm
Art. 3636-4	4 mm
Art. 3636-5	5 mm
Art. 3636-6	6 mm
Art. 3636-7	7 mm
Art. 3636-8	8 mm
Art. 3636-10	10 mm

S2
quality

7
PCS

**TX-T-Griff-Schraubendreher-
Schale**

Coquille de tournevis TX en T
Assortimento di chiavi TX a T
in vaschetta

Art.

4900-26B

↔ L1 402 × L2 173 × L3 48 mm

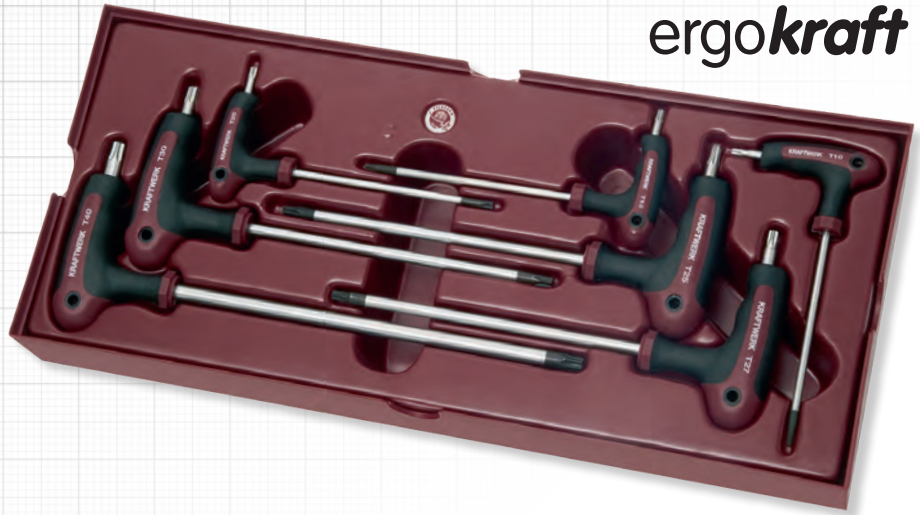

ergokraft

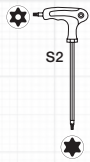

Art. 3637-10	T10
Art. 3637-15	T15
Art. 3637-20	T20
Art. 3637-25	T25
Art. 3637-27	T27
Art. 3637-30	T30
Art. 3637-40	T40

9
PCS

**Inbus-T-Griff-Stiftschlüssel-
Schale**

*Coquille de clés mâles
hexagonales en T*

Assortimento di chiavi
esagonali a T in vaschetta
con testa scorrevole

Art.

4900-35B

↔ L1 402 × L2 173 × L3 48 mm

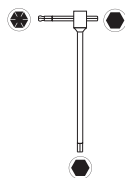

Art. 2593-02	2 mm
Art. 2593-025	2.5 mm
Art. 2593-03	3 mm
Art. 2593-04	4 mm
Art. 2593-05	5 mm
Art. 2593-06	6 mm
Art. 2593-07	7 mm
Art. 2593-08	8 mm
Art. 2593-10	10 mm



9
PCS

TX-T-Griff-Stiftschlüssel-Schale

Coquille de clés TX en T

Assortimento di chiavi TX a T in vaschetta con impugnatura scorrevole



Art.

4900-36B

↔ L1 402 × L2 173 × L3 48 mm

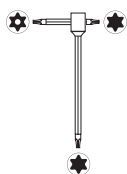

- | | |
|--------------|-----|
| Art. 2594-10 | T10 |
| Art. 2594-15 | T15 |
| Art. 2594-20 | T20 |
| Art. 2594-25 | T25 |
| Art. 2594-27 | T27 |
| Art. 2594-30 | T30 |
| Art. 2594-40 | T40 |
| Art. 2594-45 | T45 |
| Art. 2594-50 | T50 |

85
PCS

Universal-Bit-Ratschen- und Schraubwerkzeug-Schale

Coquille d'outils universels avec cliquet et embouts

Assortimento universale di inserti e giravite a percussione in vaschetta

GEARDRIVER



Art.

4900-19B

↔ L1 402 × L2 173 × L3 48 mm



- | | | |
|---|---|---------------------------------------|
| 6 | ⊖ | 4-4.5-5.5-6-6.5-8 mm |
| 4 | + | PH 1-2-3-4 |
| 4 | + | PZ 1-2-3-4 |
| 8 | ★ | T8-T10-T15-T20
T-25-T27-T30-T40 |
| 8 | ★ | T8-T10-T15-T20
T-25-T27-T30-T40 |
| 6 | ● | 3-4-5-6-7-8 mm |
| 6 | ● | 2-2.5-3-4-5-6 mm |
| 6 | ● | 5/64"-3/32"-7/64"
1/8"-9/64"-5/32" |
| 3 | + | Nos. 6-8-10 |
| 4 | + | Nos. 1-2-3-4 |
| 4 | ○ | Nos. 4-6-8-10 |

- | | | | |
|-----------|--------|---|------|
| ○ | 1/4" | ○ | 1/4" |
| ● | 1/4" | ■ | 1/4" |
| ● | 1/4" | ○ | 1/4" |
| Art. 3766 | 150 mm | | |
| Art. 3767 | 300 mm | | |
| 90 mm | | | |
| Art. 3634 | | | |
| Art. 3798 | | | |

- | | | | |
|------------|-----------------|---|-------|
| ⊖ | 6-8-10-12 mm | | |
| + | PH 1-2-3-4 | | |
| ★ | T30-T40-T45-T50 | | |
| ○ | 3/8" | ○ | 5/16" |
| ● | 5/16" | ■ | 3/8" |
| 90 mm | | | |
| 150 mm | | | |
| Art. 2035S | | | |



3/8"



16
PCS

NEU
NOUVEAU
NUOVO

Elektriker-Steckschlüssel- und Inbusschlüssel-Schale VDE
mit voll isolierter VDE-Umschaltknarre 1000V

Coquille de clés mâles et douilles d'électricien VDE
Coquille de clés mâles et douilles d'électricien VDE

Assortimento di chiavi esagonali e chiavi a bussola VDE in vaschetta
con chiave a cricchetto reversibile completamente isolato 1000V

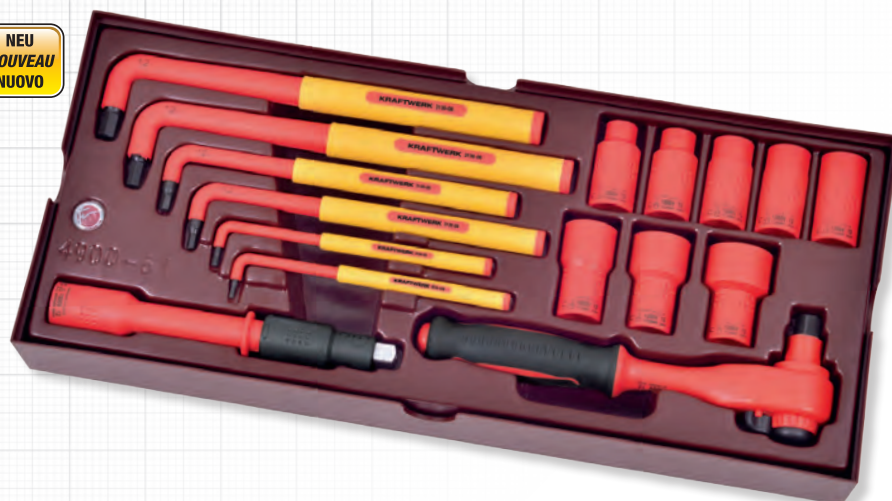

	8	8-10-12-13-14-17-19-22 mm	
	●	Art. 3136-025	2.5 × 126 mm
	●	Art. 3136-03	3.0 × 126 mm
	●	Art. 3136-04	4.0 × 160 mm
	●	Art. 3136-05	5.0 × 160 mm
	●	Art. 3136-06	6.0 × 200 mm
	●	Art. 3136-08	8.0 × 200 mm
	■	Art. 207150VDE	3/8" × 150 mm
	○	Art. 3210V	



1000 V
IEC 60900

Art.

4900-61B

↔ L1 402 × L2 173 × L3 48 mm

8
PCS

NEU
NOUVEAU
NUOVO

Elektriker-Steckschlüssel mit Griff-Schale VDE

Coquille de clés à douille emmanchée d'électricien VDE

Assortimento di giraviti a bussola VDE in vaschetta



	●	Art. 3138-07	7.0 × 125 mm
	●	Art. 3138-08	8.0 × 125 mm
	●	Art. 3138-09	9.0 × 125 mm
	●	Art. 3138-10	10.0 × 125 mm
	●	Art. 3138-11	11.0 × 125 mm
	●	Art. 3138-12	12.0 × 125 mm
	●	Art. 3138-13	13.0 × 125 mm
	●	Art. 3138-14	14.0 × 125 mm



1000 V
IEC 60900

Art.

4900-62B

↔ L1 402 × L2 173 × L3 48 mm



8
PCS

NEU
NOUVEAU
NUOVO

Elektriker-Schraubendreher-
Schale VDE

*Coquille de tournevis
d'électricien VDE*



Assortimento di giraviti VDE in
vaschetta

Art.

4900-63B

↔ L1 402 × L2 173 × L3 48 mm



	Art. 3132-1	2.5 × 75 mm
	Art. 3132-4	4.0 × 100 mm
	Art. 3132-5	5.5 × 125 mm
	Art. 3132-6	6.5 × 150 mm
	Art. 3135-0	PH0 × 60 mm
	Art. 3135-1	PH1 × 80 mm
	Art. 3135-2	PH2 × 100 mm
	Art. 2138	100-250 V

   **1000 V**
IEC 60900

10
PCS

NEU
NOUVEAU
NUOVO

Elektriker-TX-
Schraubendreher-Schale VDE

mit Bohrung an der Spitze für TX-
Schrauben mit und ohne Sicherungsstift

*Coquille de tournevis TX
d'électricien VDE*

*avec pointe percée, pour vis TX normales
et TX vis de sécurité*

Assortimento di giraviti TX
VDE in vaschetta

con perforazione sulla punta, per viti TX
normali e viti TX con pin di sicurezza

Art.

4900-64B

↔ L1 402 × L2 173 × L3 48 mm



	Art. 3133-06	T6 × 100 mm
	Art. 3133-07	T7 × 100 mm
	Art. 3133-08	T8 × 100 mm
	Art. 3133-10	T10 × 100 mm
	Art. 3133-15	T15 × 100 mm
	Art. 3133-20	T20 × 100 mm
	Art. 3133-25	T25 × 125 mm
	Art. 3133-27	T27 × 125 mm
	Art. 3133-30	T30 × 150 mm
	Art. 3133-40	T40 × 175 mm

   **1000 V**
IEC 60900

10
PCS

Elektriker-Innensechskant-Schraubendreher- und Winkelstiftschlüssel-Schale VDE
Coquille de clés mâles et tournevis à six pans creux d'électricien VDE
Assortimento di chiavi e giraviti maschio esagonali VDE in vaschetta

Art.
4900-65B

↔ L1 402 × L2 173 × L3 48 mm

NEU
NOUVEAU
NUOVO

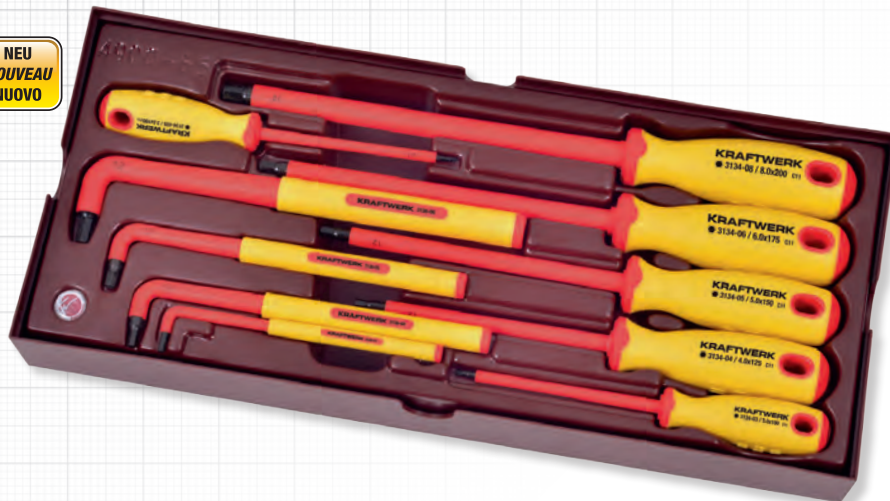

VDE GS 1000 V IEC 60900

	● Art. 3134-025	2.5 × 100 mm
	● Art. 3134-03	3.0 × 100 mm
	● Art. 3134-04	4.0 × 125 mm
	● Art. 3134-05	5.0 × 150 mm
	● Art. 3134-06	6.0 × 175 mm
	● Art. 3134-08	8.0 × 200 mm

	● Art. 3136-03	3.0 × 126 mm
	● Art. 3136-04	4.0 × 160 mm
	● Art. 3136-05	5.0 × 160 mm
	● Art. 3136-06	6.0 × 200 mm

6
PCS

Elektriker-Zangen- und Schneidwerkzeug-Schale VDE
Coquille de pinces et outils de coupe d'électricien VDE
Assortimento di pinze ed utensili da taglio VDE in vaschetta





Art.
4900-67B

↔ L1 402 × L2 173 × L3 48 mm

NEU
NOUVEAU
NUOVO

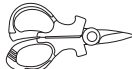

ergokraft

	Art. 3281-180V	180 mm
	DIN ISO 5746	
	Art. 3282-160V	160 mm
	DIN ISO 5749	
	Art. 3285-200V	200 mm
	DIN ISO 5745	
	Art. 2251V	
	Art. 3321V	
	4pcs. Art. 3321-4V	

VDE GS 1000 V IEC 60900

HYBRID

4
PCS

Elektriker-Zangen-Schale VDE

*Coquille de pinces
d'électricien VDE*

Assortimento di pinze VDE
per elettricista in vaschetta

Art.

4900-43B

↔ L1 402 × L2 173 × L3 48 mm



Art. 4211-180 180 mm **K C H**
DIN ISO 5746



Art. 4212-160 160 mm **K C H**
DIN ISO 5749



Art. 4215-205 200 mm **C H**
DIN ISO 5745



Art. 4219-160 160 mm
DIN ISO 5232



220 N/mm² 1800 N/mm²

Made in Germany



1000 V
IEC 60900



ergokraft

4
PCS

Elektriker-Zangen-Schale VDE

*Coquille de pinces
d'électricien VDE*

Assortimento di pinze VDE
per elettricista in vaschetta

Art.

4900-42B

↔ L1 402 × L2 173 × L3 48 mm



Art. 3281-180V 180 mm
DIN ISO 5746



Art. 3282-160V 160 mm
DIN ISO 5749



Art. 3285-200V 205 mm
DIN ISO 5745



Art. 3289-160V 160 mm
DIN ISO 5232



1000 V
IEC 60900

4
PCS

NEU
NOUVEAU
NUOVO

Industrie-Zangen-Schale
mit 3-Komponenten-Griffen

*Coquille de pinces industrielles
avec des manches 3-composants*

**Assortimento di pinze
industriali in vaschetta**
con maniglie di 3 componenti

Art.

4900-33B

↔ L1 402 × L2 173 × L3 48 mm



HIGHTECH3C

Made in Germany



Art. 4271-180 180 mm **K C H**
DIN ISO 5746



Art. 4272-160 160 mm **K C H**
DIN ISO 5749



Art. 4275-205 205 mm **C H**
DIN ISO 5745



Art. 4279-160 160 mm
DIN ISO 5232



220 N/mm² 1800 N/mm²



4
PCS

Zangen-Schale

Coquille de pinces

**Assortimento di pinze
in vaschetta**

Art.

4900-07B

↔ L1 402 × L2 173 × L3 48 mm



ergokraft



Art. 3281-180 180 mm
DIN ISO 5746



Art. 3282-160 160 mm
DIN ISO 5749



Art. 3285-200 200 mm
DIN ISO 5745



Art. 3289-160 160 mm
DIN ISO 5232

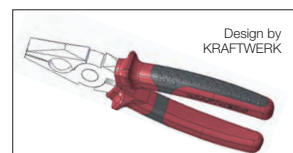

5
PCS

NEU
NOUVEAU
NUOVO

Universal-Zangen-Schale
Coquille de pinces universelles
Assortimento di pinze universali in vaschetta



Art.	
4900-57B1	4224-250
4900-57B2	4223-240
4900-57B3	4222-250

↔ L1 402 × L2 173 × L3 48 mm

4900-57B1 / Art. 4224-250

Made in Germany **HIGHTECH**

4GRIP

50 mm

250 mm

DIN ISO + 40%

drag&drop

Made in Germany Art. 4276-205 205 mm
DIN ISO 5745

HIGHTECH-IC



Art. 3292-250 max. 250/10"

CrMo



Art. 3290-230 230 mm

ergokraft



1.5 - 6 mm² 1.5 - 4.6 mm²



VICTORINOX

4900-57B2 / Art. 4223-240

Made in Germany

50 mm

240 mm

DIN ISO 8976

Made in Germany Art. 4276-205 205 mm
DIN ISO 5745

HIGHTECH-IC



Art. 3292-250 max. 250/10"

CrMo



Art. 3290-230 230 mm

ergokraft



1.5 - 6 mm² 1.5 - 4.6 mm²



VICTORINOX

4900-57B3 / Art. 4222-250

Made in Germany

50 mm

250 mm

DIN ISO 8976

Made in Germany Art. 4276-205 205 mm
DIN ISO 5745

HIGHTECH-IC



Art. 3292-250 max. 250/10"

CrMo



Art. 3290-230 230 mm

ergokraft



1.5 - 6 mm² 1.5 - 4.6 mm²

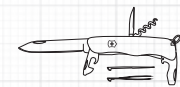

VICTORINOX

4
PCS

Universal-Zangen-Schale
Coquille de pinces universelles
Assortimento di pinze universali in vaschetta

Art.

4900-08B

↔ L1 402 × L2 173 × L3 48 mm

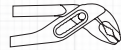

Art. 2221-250 250 mm
DIN ISO 8976



Art. 2216-200 200 mm
DIN ISO 9243



Art. 2262-07 7-1/2" 195 mm

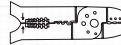

Art. 2225 240 mm 1.5 - 6 mm² 1.5 - 4.6 mm²

4
PCS

Seegerring-Zangen-Schale
Coquille de pinces pour circlips
Assortimento di pinze per anelli Seeger in vaschetta

Art.

4900-09B

↔ L1 402 × L2 173 × L3 48 mm

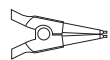

Art. 2212-A2 A2
DIN ISO 5254A

Ø 19-60 mm

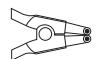

Art. 2213-A21 A21
DIN ISO 5254B



Art. 2214-J2 J2
DIN ISO 5256C



Art. 2215-J21 J21
DIN ISO 5256D

COMPLETO Serie 4900 ergokraft

5
PCS

Rollgabelschlüssel- und
Zangen-Schale

*Coquille de clés à molette
et pinces*

Assortimento di pinze
autobloccanti, chiavi a rullino
e cesoia in vaschetta



Art.

4900-21B

↔ L1 402 × L2 173 × L3 48 mm



ergokraft

Art. 3572 150 mm / 6" ○ 0-13 mm

Art. 3573 200 mm / 8" ○ 0-25 mm

DIN 3117 / ISO 6787



ergokraft

Art. 2243 250 mm HRC 58-60



Art. 3292-175 175 mm / 7" CrMo



Art. 3292-150 150 mm / 6" CrMo

11
PCS

Feilen-Schale

Coquille de limes

Assortimento di lime
in vaschetta



ergokraft

Art.

4900-10B

↔ L1 402 × L2 173 × L3 48 mm



Art. 4320-1 320 mm

DIN 7261



Art. 4320-2 320 mm

DIN 7261



Art. 4320-3 320 mm

DIN 7261



Art. 4320-4 320 mm

DIN 7261



Art. 4320-5 320 mm

DIN 7261

▮▮▮▮▮▮ Art. 4321

22
PCS

Schneidwerkzeug-Schale
Coquille d'outils de coupe
Assortimento di attrezzi da taglio in vaschetta

Art.





4900-11B

↔ L1 402 × L2 173 × L3 48 mm

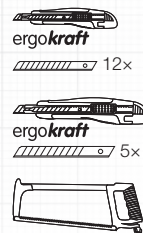

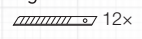
ergokraft

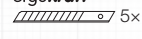

- | | | |
|---|-----------|--------|
|  | Art. 3310 | 9 mm |
|  | Art. 3313 | 9 mm |
|  | Art. 3312 | 18 mm |
|  | Art. 3314 | 18 mm |
|  | Art. 3305 | 300 mm |

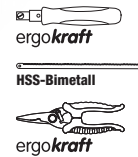

- | | | |
|--|--------------|--------|
|  | Art. 3308-1 | |
|  | Art. 3316-24 | 300 mm |
|  | Art. 2240 | |

11
PCS

Schlagwerkzeug-Schale
Coquille d'outils de frappe
Assortimento di attrezzi a percussione in vaschetta

Art.

4900-56B Art. 2305 500 g

4900-66B Art. 2319 500 g

↔ L1 402 × L2 173 × L3 48 mm

NEU
NOUVEAU
NUOVO









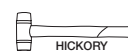
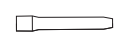

4900-56B / Art. 2305

4900-56B / Art. 2305



4900-66B / Art. 2319



- | | | |
|---|------------------------|---------|
|  | Art. 2336 | Ø 35 mm |
|  | Art. 3380-18 | 18 mm |
|  | Art. 3380-22 | 22 mm |
| | DIN 6451/53 | |
|  | Art. 1350-2 | 2 mm |
|  | Art. 1350-3 | 3 mm |
|  | Art. 1350-4 | 4 mm |
|  | Art. 1350-5 | 5 mm |
|  | Art. 1350-6 | 6 mm |
|  | Art. 1350-8 | 8 mm |
| | DIN 6450 Form C | |
|  | Art. 1358-2 | No. 2 |
| | DIN 7250 | |

9
PCS



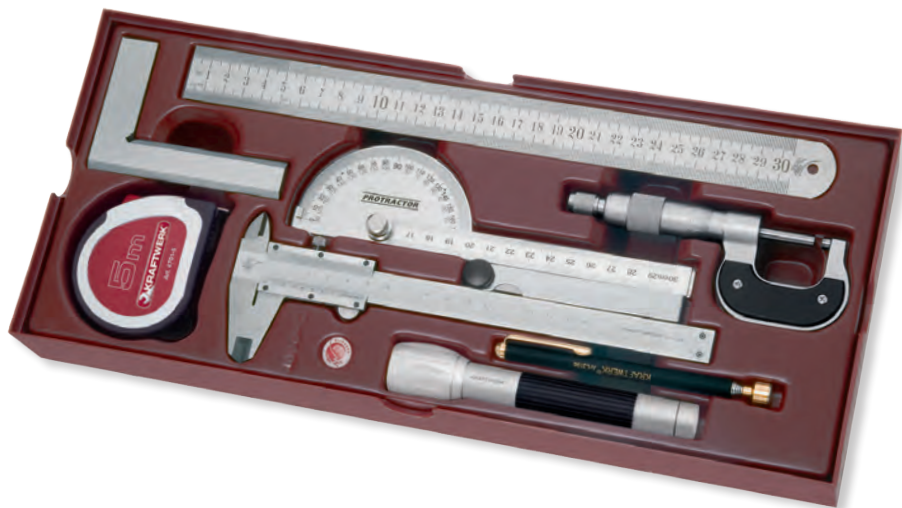





Messwerkzeug-Schale
Coquille d'outils de mesure
Assortimento di strumenti di misura in vaschetta



Art.

4900-12B

↔ L1 402 × L2 173 × L3 48 mm

	Art. 4701-0519	5 m × 19 mm	
	Art. 2970	150 mm × 0.05 mm	6" × 1/128"
	Art. 2975	0-25 mm × 0.01 mm	
	Art. 2976	300 mm × 28 mm	
	Art. 2977	200 mm	
	Art. 2978	100 mm × 70 mm	
	Art. 2974	0.05-0.1-0.15-0.2-0.3-0.4-0.5-0.6-0.7-0.8 mm	
	Art. 3196	130-630 mm / 2000 g	
	Art. 4996		

HSS-G **40**
PCS







Bohr- und Gewindeschneidwerkzeug-Schale
Coquille de tarauds et filières
Assortimento di maschi, filiere e punte in vaschetta

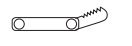

Art.

4900-34B

↔ L1 402 × L2 173 × L3 48 mm

	Art. 23030	M3			Art. 11904	1-1.5-2-2.5-3-3.5-4
	Art. 23040	M4			DIN 338 N	4.5-5-5.5-6-6.5-7-7.5
	Art. 23050	M5				8-8.5-9-9.5-10 mm
	Art. 23060	M6				
	Art. 23080	M8			Art. 11033	3.3 mm
	Art. 23100	M10			Art. 11042	4.2 mm
	Art. 23120	M12			Art. 11068	6.8 mm
					Art. 11102	10.2 mm
					DIN 338 N	
	Art. 24200	0.25-6 mm / 60°			Art. 25030	M3
	Art. 24015	M2-M12			Art. 25040	M4
	DIN 1814				Art. 25050	M5
	Art. 24110	M3-M10			Art. 25060	M6
	DIN 1814				Art. 25080	M8
					Art. 25100	M10
					Art. 25120	M12
					DIN 371	

HSS-G **42**
PCS

NEU
NOUVEAU
NUOVO

Bohr- und Gewinde-
schneidwerkzeug-Schale
Coquille de tarauds et filières
Assortimento di maschi,
filiere e punte in vaschetta



Art.
4900-59B

↔ L1 402 × L2 173 × L3 48 mm



- Art. 26030 M3
- Art. 26040 M4
- Art. 26050 M5
- Art. 26060 M6
- Art. 26080 M8
- Art. 26100 M10
- Art. 26120 M12
- DIN / ISO 261**

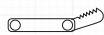

- Art. 24200 0,25-6 mm / 60°



- Art. 24010 M3-M12
- DIN 225**



- Art. 24015 M2-M12
- DIN 1814**



- Art. 24110 M3-M10
- DIN 1814**



- Art. 11904 1-1.5-2-2.5-3-3.5-4
- DIN 338 N** 4.5-5-5.5-6-6.6-7-7.5
- 8-8.5-9-9.5-10 mm



- Art. 11033 3.3 mm
- Art. 11042 4.2 mm
- Art. 11068 6.8 mm
- Art. 11102 10.2 mm
- DIN 338 N**



- Art. 25030 M3
- Art. 25040 M4
- Art. 25050 M5
- Art. 25060 M6
- Art. 25080 M8
- Art. 25100 M10
- Art. 25120 M12
- DIN 371**



- Art. 3240S Ø 0.5 mm

HSS-G **77**
PCS

Gewinde-Einsatz-
Werkzeug-Schale
Coquille kit de réparation
filets
Assortimento di filetti
riportati in vaschetta



Art.
4900-51B

↔ L1 402 × L2 173 × L3 48 mm



- M4-M12, M6-M20
- 3/18"-1/2", 1/4"-3/4"



- M5×0.8, M6×1.0,
- M8×1.25, M10×1.5,
- M12×1.75, M14×1.25



- M5×0.8, M6×1.0,
- M8×1.25, M10×1.5,
- M12×1.75, M14×1.25



- M5×0.8, M6×1.0,
- M8×1.25, M10×1.5,
- M12×1.75, M14×1.25



- 215-640 mm



- 0.5-1.75 mm



- 16 M5-0.8
- 12 M6-1.0
- 10 M8-1.25
- 6 M10-1.5
- 5 M12-1.75
- 4 M14-1.25



HSS
bimetal

16
PCS

M42+8%Co

Lochsägen-Schale
Coquille de scies trépan
Assortimento di seghe a tazza
in vaschetta

Art.	
4900-39B	
4900-39BS	NEU NOUVEAU NUOVO

↔ L1 402 × L2 173 × L3 48 mm



	Art. 19001		Art. 19005	14-30 mm / 3/8"
	Art. 19002		Art. 19006	32-76 mm / 7/16"
	Art. 19003			300 mm / 3/8"
	Art. 19190	19 mm	Art. 19380	38 mm
	Art. 19200	20 mm	Art. 19440	44 mm
	Art. 19220	22 mm	Art. 19510	51 mm
	Art. 19250	25 mm	Art. 19570	57 mm
	Art. 19290	29 mm	Art. 19680	68 mm
	Art. 19320	32 mm	Art. 19760	76 mm
	Art. 19350	35 mm		

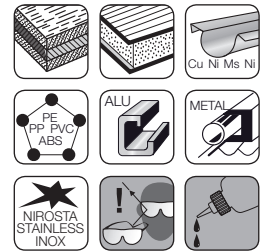

Werkstatt-LED-Lampen-
Schale
Coquille de lampes LED
d'atelier
Assortimento di lampade
LED in vaschetta

Art.	LIGHT Art.
4900-52B	32022 + 32001UV + 32051
4900-53B	32022 + 32001 + 32051

↔ L1 402 × L2 173 × L3 48 mm

NEU
NOUVEAU
NUOVO

8
PCS



LIGHT

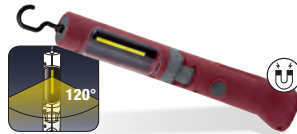

Art. 32022
↔ 285 mm, Ø 40 mm



4900-52B / Art. 32001UV
4900-53B / Art. 32001
↔ 250 mm, Ø 36 mm



Art. 32051
↔ 145 mm, Ø 28 mm

3W COB LED
80-100 LUX
170-200 lm
* Chip On Board/sur circuit imprimé

Li-Ion 3.7 V
(4000 mAh)

4900-52B / Art. 32001UV
18 + 4 UVLED
500 LUX (1m) + 120 LUX (1m)

4900-53B / Art. 32001
18 + 4 LED
500 LUX (1m) + 120 LUX (1m)

GREE 3 W
1 LED
80 lm

0-200 m ZOOM

100-240 V / 50/60 Hz

12-24 V

4
PCS

NEU
NOUVEAU
NUOVO

Foto-/Video-Endoskop-Schale
Coquille de photo- / vidéo-endoscope
Assortimento endoscopio Foto/ Video in vaschetta



Art.	Ø mm	L	
4900-45B-0391	3.9	1 m	flex
4900-45B-0393	3.9	3 m	flex
4900-45B-0550*	5.5	1 m	mem
4900-45B-0551*	5.5	1 m	flex
4900-45B-0553*	5.5	3 m	flex
4900-45B-0800	8.0	1 m	mem
4900-45B-0801	8.0	1 m	flex
4900-45B-1200	12.0	1 m	mem

↕ L1 402 × L2 173 × L3 48 mm



↕ L1 94 × L2 78 × L3 10 mm

Display 3.5" / 89 mm TFT
640 × 480 pixel
16.7 Mio. Colors / 30 bps

Video PAL / NTSC

Sensor CMOS

Batterie Li-Polymer-Akku 3.7 V 2000 mAh
(100-240 V / 50-60 Hz)

Memory SD Card **2GB** (max. **8GB**)
IP67

flex = flexibel / souple / flexible
mem = halbstarr / rigide / rigido

* Längere Kabel auf Anfrage
Des câbles plus longs sur demande
Cavi più lunghi su richiesta

inklusive / inclus / incluso:

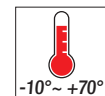
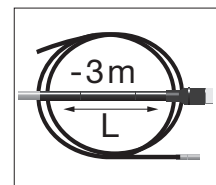
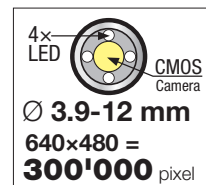
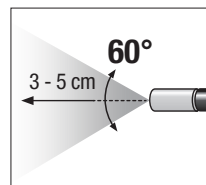

Optional / Option / Opzionali :
4900-45B-0550 / 4900-45B-0551 / 4900-45B-0553

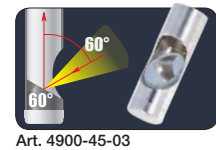
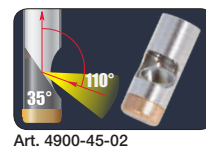

Kleinteile-Schale
Coquilles pour petites pièces
Vaschetta portaminuteria

Art.

4900-37B

↕ L1 402 × L2 173 × L3 48 mm



ABS-Schale
leer
Coquille en ABS
vide
Scomparto in ABS
vuoto

Art.

4900E

↕ L1 402 × L2 173 × L3 48 mm

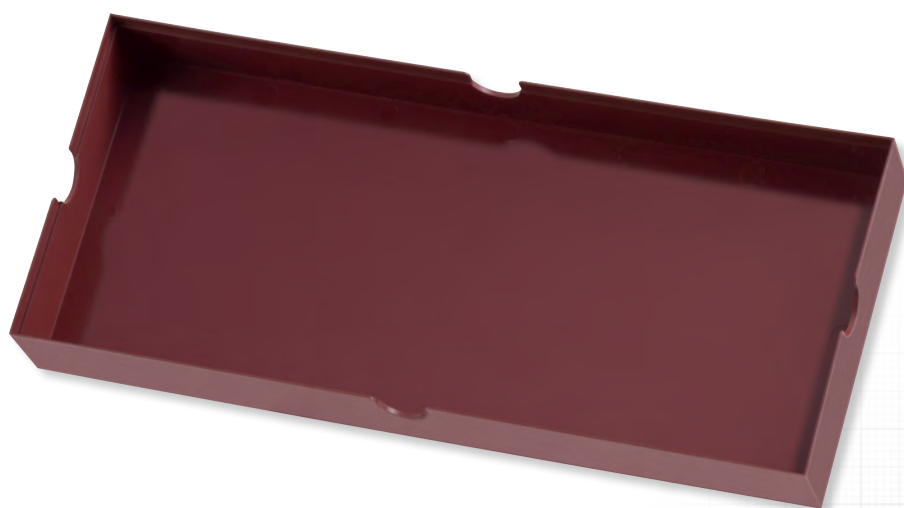

ABS-Tragkoffer

für COMPLETEO-Schalen, leer

Coffret en ABS

pour coquilles COMPLETEO, vide

Valigetta ABS

per assortimenti COMPLETEO, vuota

Art.

4900K

↕ L1 421 × L2 200 × L3 68 mm



SEL11

Werkzeugtasche

Praktisch und solid mit Tragriemen und 4 seitlichen Werkzeugfächern sowie grossem Werkzeugfach auf der Oberseite. Bietet Platz für 6 **COMPLETO**-Schalen.

Sacoche de transport

en bandoulière pratique et solide composée de quatre compartiments en façade plus un sur le dessus, pouvant accueillir 6 modules **COMPLETO**.

Valigia per utensili

Solida e pratica. Tasca anteriore esterna, una interna e due laterali. Comoda tracolla. Accoglie 6 assortimenti **COMPLETO**.

Art.

4900T

↔ L1 450 × L2 360 × L3 230 mm



Werkzeugtasche

mit 4 Leerschalen

Sacoche de transport

avec 4 coquilles vides

Valigia per utensili

con 4 vaschette vuote

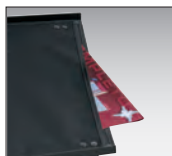

Art.

4900TS

4 × 4900E

↔ L1 450 × L2 360 × L3 230 mm



Video

[KRAFTWERKtools.com/video/4900T](https://www.kraftwerktools.com/video/4900T)

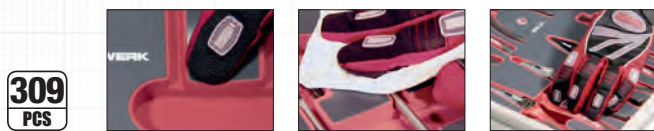
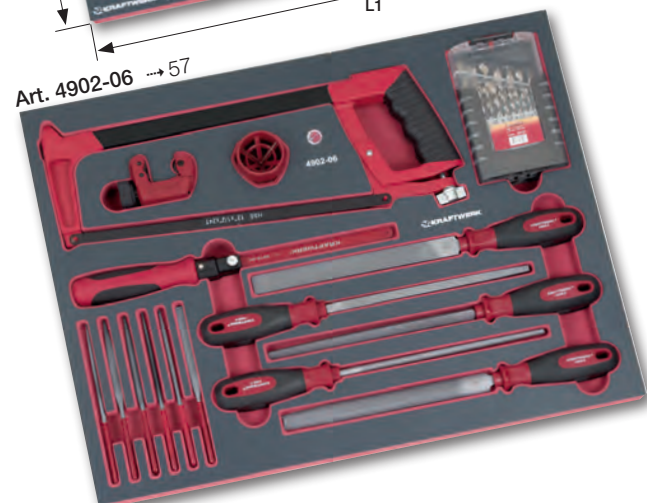
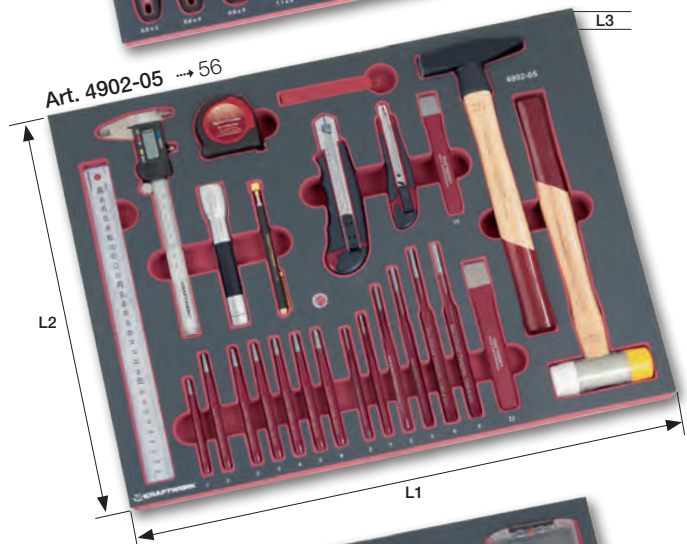
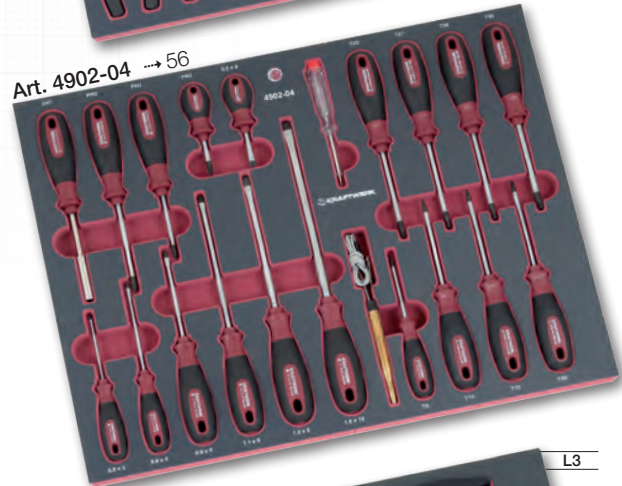
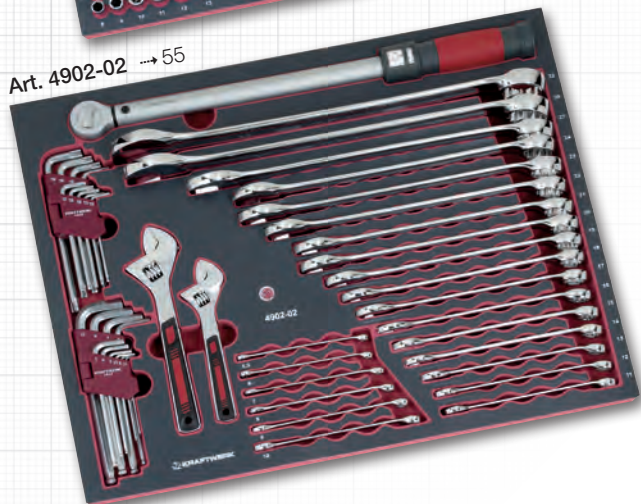
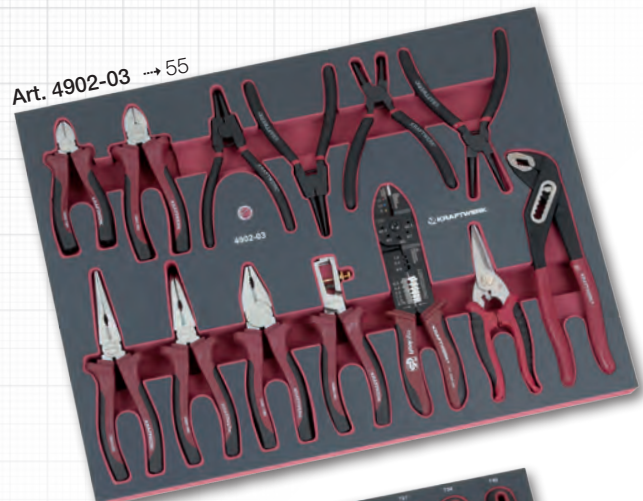
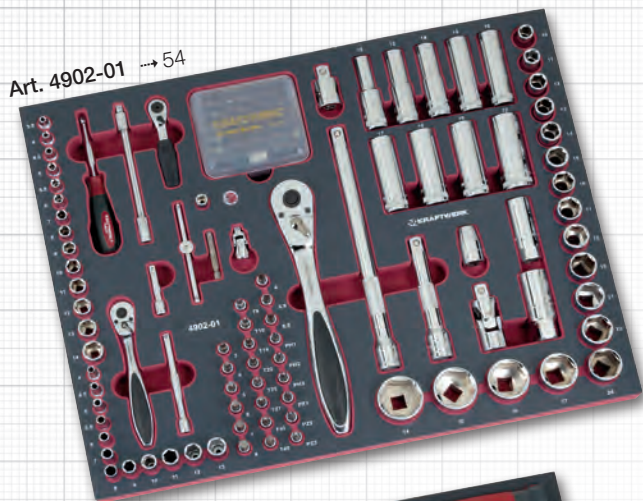

309
PCS

Werkzeug-Zusammenstellung

mit professionellen Werkzeugen, schüttelfest eingebettet in 6 Schubladen in speziell hochverdichteten Weich-Schaumstoff-Einlagen (EVA) mit einer dauerhaften Hartplastik-Oberschicht, die gereinigt werden kann.

Sélection d'outils professionnels

répartis dans 6 tiroirs garnis de nos inserts mousse (EVA) de haute densité avec revêtement renforcé garantissant ainsi une durée de vie plus longue et un nettoyage aisé.

Set utensili professionali

riposti in 6 esclusivi vassoi "anti-rovesciamento" realizzati in materiale espanso ad alta densità (EVA). Il top di questi vassoi è in laminato e ciò garantisce una maggior durata e una pulizia più facile.

Art. 

4917

HIGHTECH / KRAFTWERK RACING

↕ L1 527 × L2 407 × L3 30 mm



Video

[KRAFTWERKtools.com/video/4917](https://www.kraftwerktools.com/video/4917)

COMPLETO EVA Serie 4902

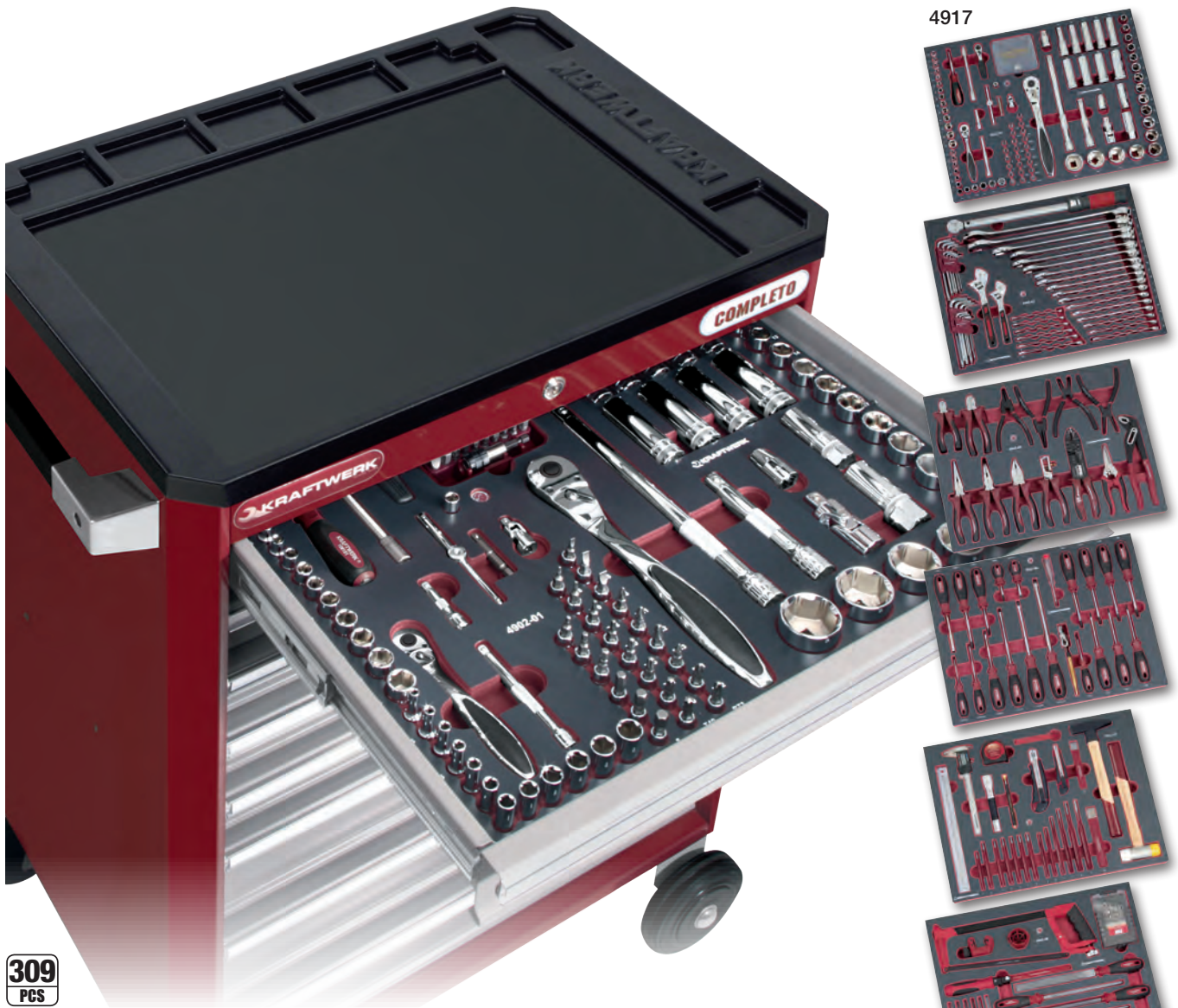

309
PCS

NEU
NOUVEAU
NUOVO

Werkzeug-Zusammenstellung
mit Werkstattwagen
*Assortiment d'outils
avec servantes*
Assortimento di utensili
con carrelli



Art.			
3908-4917	3908	8	3
3909-4917	3909	11	4
2907-4917	2907	7	7



Steckschlüssel-Satz
Jeu de douilles
Assortimento di chiavi
e bussole

Art.
4902-01

↔ L1 527 × L2 407 × L3 30 mm

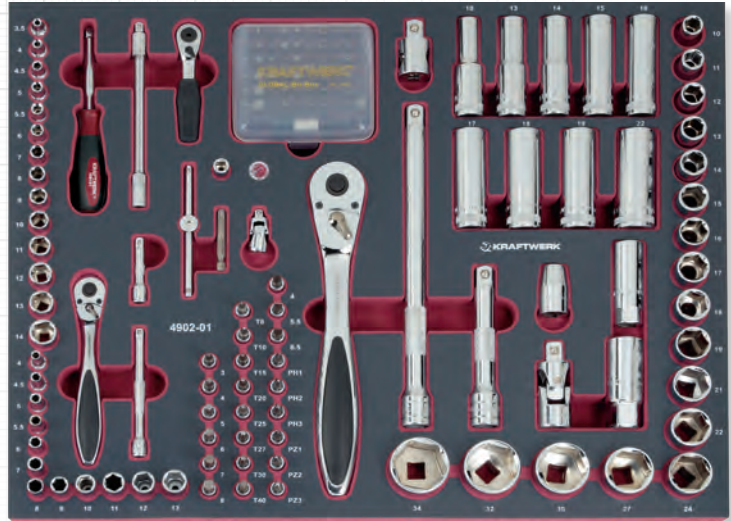

- | | | | | | |
|--|----|--|--|----|--|
| | 14 | 3.5-4-4.5-5-5.5-6-7-8
9-10-11-12-13-14 mm | | 17 | 10-11-12-13-14-15-16-17-18
19-21-22-24-27-30-32-34 mm |
| | 12 | 4-4.5-5-5.5-6-7-8-9
10-11-12-13 mm | | 9 | 10-13-14-15-16-17-18
19-22 mm |
| | 3 | 4-5.5-6.5 mm | | 2 | 16 mm / 21 mm |
| | 3 | PH 1-2-3 | | | □ 1/2" □ 1/2" |
| | 3 | PZ 1-2-3 | | 2 | 125 mm / 250 mm |
| | 8 | T8-T10-T15-T20
T25-T27-T30-T40 | | | □ 3/8" □ 1/2" |
| | 6 | 3-4-5-6-7-8 mm | | | □ 1/2" □ 5/16" |
| | | □ 1/4" □ 1/4" | | | 60 Art. 4020B |
| | | □ 1/4" □ 1/4" | | | |
| | 2 | 50 mm / 100 mm | | | |
| | | 150 mm | | | |
| | | 105 mm | | | |
| | | □ 1/4" □ 1/4" | | | |
| | | ■ 1/4" ■ 1/4" | | | |

- | | | |
|--|----|------------|
| | 72 | Art. 3799 |
| | 60 | Art. 4000B |

- | | | |
|--|---|------------------------------------|
| | 6 | 4-4.5-5.5-6-6.5-8 mm |
| | 4 | PH 1-2-3-4 |
| | 4 | PZ 1-2-3-4 |
| | 8 | T8-T10-T15-T20-T25-T27-T30-T40 |
| | 8 | T8-T10-T15-T20-T25-T27-T30-T40 |
| | 6 | 3-4-5-6-7-8 mm |
| | 6 | 2-2.5-3-4-5-6 mm |
| | 6 | 5/64"-3/32"-7/64"-1/8"-9/64"-5/32" |
| | 3 | Nos. 6-8-10 |
| | 4 | Nos. 1-2-3-4 |
| | 4 | Nos. 4-6-8-10 |

1/4" 1/4" 1/4" 1/4"



GLOBALBIT-Box
Art. 3777

101 × 90 × 32 mm

61
PCS



45
PGS

Schraubenschlüssel- und Drehmomentschlüssel-Satz

Jeu de clés avec clé dynamométrique

Assortimento di chiavi e chiave dinamometrica

Art.

4902-02

↔ L1 527 × L2 407 × L3 30 mm

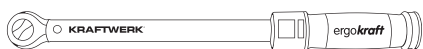

Art. 3235 1/2" 40-200 Nm / 30-150 Lb.ft

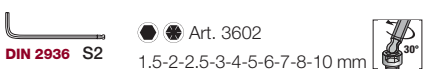

DIN 2936 S2 Art. 3602 1.5-2-2.5-3-4-5-6-7-8-10 mm

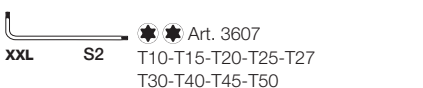

XXL S2 Art. 3607 T10-T15-T20-T25-T27 T30-T40-T45-T50

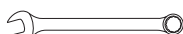

DIN 3113

Art. 3505	5.5 mm	Art. 3511	11 mm	Art. 3517	17 mm	Art. 3523	23 mm
Art. 3506	6 mm	Art. 3512	12 mm	Art. 3518	18 mm	Art. 3524	24 mm
Art. 3507	7 mm	Art. 3513	13 mm	Art. 3519	19 mm	Art. 3527	27 mm
Art. 3508	8 mm	Art. 3514	14 mm	Art. 3520	20 mm	Art. 3530	30 mm
Art. 3509	9 mm	Art. 3515	15 mm	Art. 3521	21 mm	Art. 3532	32 mm
Art. 3510	10 mm	Art. 3516	16 mm	Art. 3522	22 mm		



ergokraft

DIN 3117 / ISO 6787

Art. 3572 150 mm / 6"
Art. 3573 200 mm / 8"

13
PGS

Zangen-Satz

Jeu de pinces

Assortimento di pinze

Art.

4902-03

↔ L1 527 × L2 407 × L3 30 mm



Art. 3281-180 180 mm
DIN ISO 5746

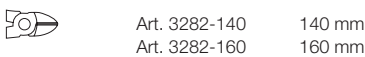

Art. 3282-140 140 mm
Art. 3282-160 160 mm
DIN ISO 5749

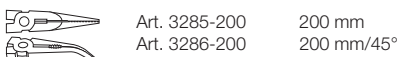

Art. 3285-200 200 mm
Art. 3286-200 200 mm/45°
DIN ISO 5745



Art. 3289-160 160 mm
DIN ISO 5232



Art. 2221-250 250 mm
DIN ISO 8976



Art. 2240 180 mm
ergokraft



Art. 2212-A2 A2
DIN ISO 5254A



Art. 2213-A21 A21
DIN ISO 5254B



Ø 19-60 mm



Art. 2214-J2 J2
DIN ISO 5256C



Art. 2215-J21 J21
DIN ISO 5256D



Art. 3290-230 230 mm
1.5 - 6 mm² 1.5 - 4-6 mm²
ergokraft

35
PCS

Feilen-/Sägen- und Bohrer-Satz

Jeu de limes, de scies et de forets









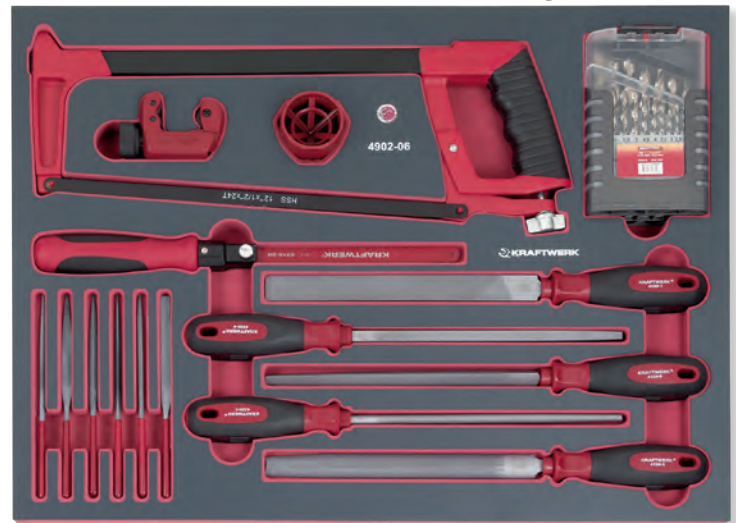

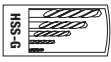

Assortimento di lime, seghetti e punte

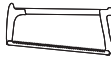
Art.

4902-06

↔ L1 527 × L2 407 × L3 30 mm



	Art. 4320-1 320 mm DIN 7261		Art. 4321		Art. 11904 DIN 338 N	1-1.5-2-2.5-3 3.5-4-4.5-5-5.5 6-6.5-7-7.5-8 8.5-9-9.5-10 mm
	Art. 4320-2 320 mm DIN 7261		Art. 3305 300 mm		Art. 5433	3-30 mm CU
	Art. 4320-3 320 mm DIN 7261		Art. 3308-1		Art. 5470	Ø 4-40 cm
	Art. 4320-4 320 mm DIN 7261		Art. 3316-24 300 mm			
	Art. 4320-5 320 mm DIN 7261					

12
PCS

T-Griff-Gelenkschlüssel-Satz extra lang

Jeu de clés articulées en T extra longues

Assortimento di chiavi esagonali snodate a T extra lunghi

Art.

4902-07

↔ L1 527 × L2 407 × L3 30 mm



	XXL	DIN 896 / ISO 2236, 1085	
Art. 2592-08	8 mm	Art. 2592-14	14 mm
Art. 2592-09	9 mm	Art. 2592-15	15 mm
Art. 2592-10	10 mm	Art. 2592-16	16 mm
Art. 2592-11	11 mm	Art. 2592-17	17 mm
Art. 2592-12	12 mm	Art. 2592-18	18 mm
Art. 2592-13	13 mm	Art. 2592-19	19 mm

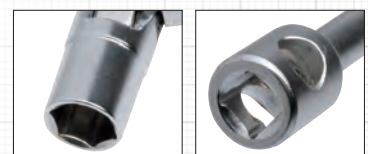



21
PCS

NEU
NOUVEAU
NUOVO

Steckschlüsselsatz für den Schwersteinsatz

mit Feinzahn-Umschaltknarre mit Stecknuss-Auswurf-Mechanismus. Verlängerungen mit Verriegelungs-System.

Jeu de douilles pour poids lourds

avec cliquet à denture fine avec mécanisme d'éjection de douilles et rallonges avec système de verrouillage.

Assortimento di chiavi a bussola per impieghi pesanti

con chiave a cricchetto a denti fini con meccanismo di sgancio rapido e sistema di bloccaggio.

Art.
4902-08

↔ L1 527 × L2 407 × L3 40 mm

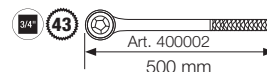
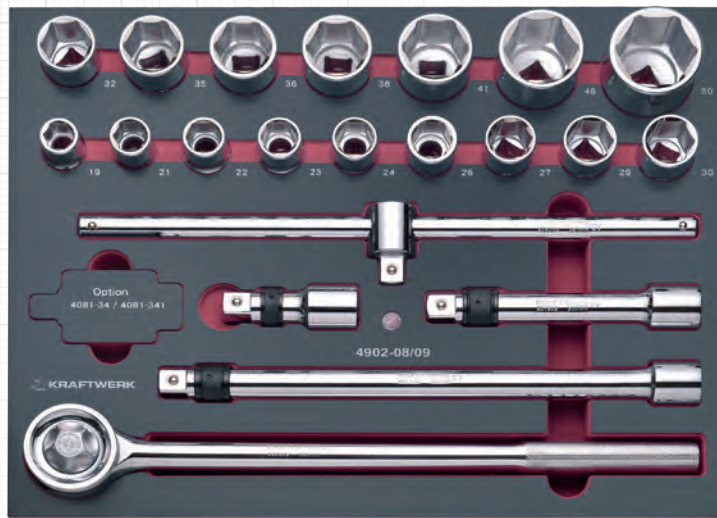

16 19-21-22-23-24-26-27-29-30
32-35-36-38-41-46-50 mm



3 100-200-400 mm



460 mm



22
PCS



Steckschlüsselsatz für den Schwersteinsatz

mit Digital-Drehmoment-Adapter

Jeu de douilles pour poids lourds

avec adaptateur dynamométrique digital

Assortimento di chiavi a bussola per impieghi pesanti

con adattore dinamometrico digitale

Art.	
4902-080	4081-34
4902-081	4081-341

↔ L1 527 × L2 407 × L3 40 mm

NEU
NOUVEAU
NUOVO

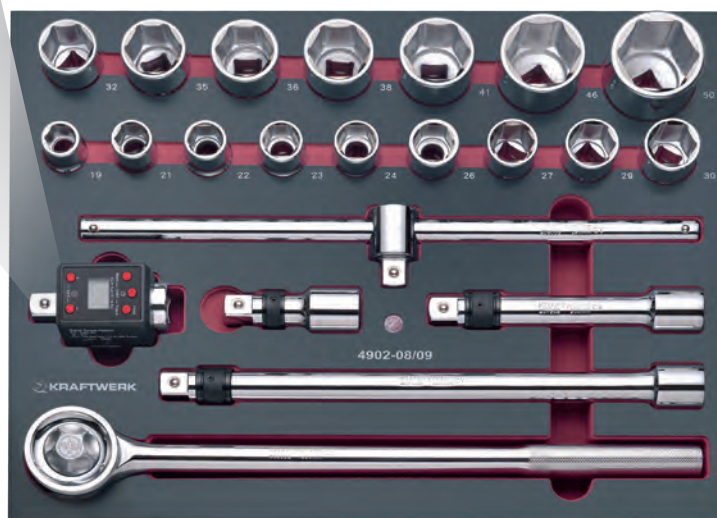

16 19-21-22-23-24-26-27-29-30
32-35-36-38-41-46-50 mm

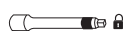

3 100-200-400 mm

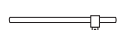

460 mm

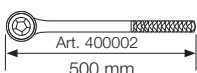

4902-080 / Art. 4081-34



Art. **4081-34**
100-500 Nm (± 2%) / 73.8-369 Lb.ft
kg-m / kg-cm / lb-in / ft-lbs

4902-081 / Art. 4081-341



Art. **4081-341**
200-1000 Nm (± 2%) / 147.6-738 Lb.ft
kg-m / kg-cm / lb-in / ft-lbs



21
PCS

NEU
NOUVEAU
NUOVO

Steckschlüsselsatz für den Schwersteinsatz

mit fein verzahnter **Teleskop**-Auszug-
Umschaltknarre mit Stecknuss-Auswurf-
Mechanismus. Verlängerungen mit
Verriegelungs-System.

Jeu de douilles pour poids lourds

avec cliquet à denture fine avec manche
téléscopique et mécanisme d'éjection
de douilles. Rallonges avec système de
verrouillage.

Assortimento di chiavi a bussola per impieghi pesanti

con chiave a cricchetto **estensibile** a denti
fini con meccanismo di sgancio rapido e
sistema di bloccaggio.

Art.

4902-09

↕ L1 527 × L2 407 × L3 40 mm

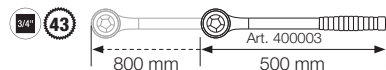
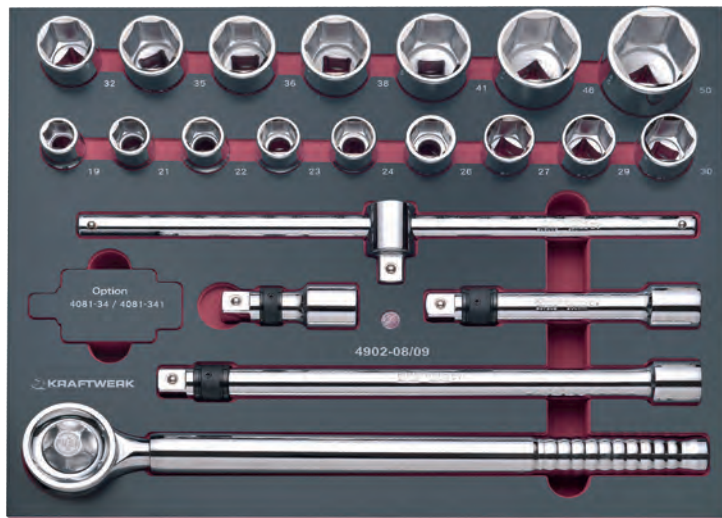

3/4" 16 19-21-22-23-24-26-27-29-30
32-35-36-38-41-46-50 mm

3 100-200-400 mm

460 mm



22
PCS



Steckschlüsselsatz für den Schwersteinsatz

mit Digital-Drehmoment-Adapter

Jeu de douilles pour poids lourds

avec adaptateur dynamométrique digital

Assortimento di chiavi a bussola per impieghi pesanti

con adattore dinamometrico digitale

Art.



4902-090

4081-34

4902-091

4081-341

↕ L1 527 × L2 407 × L3 40 mm

NEU
NOUVEAU
NUOVO

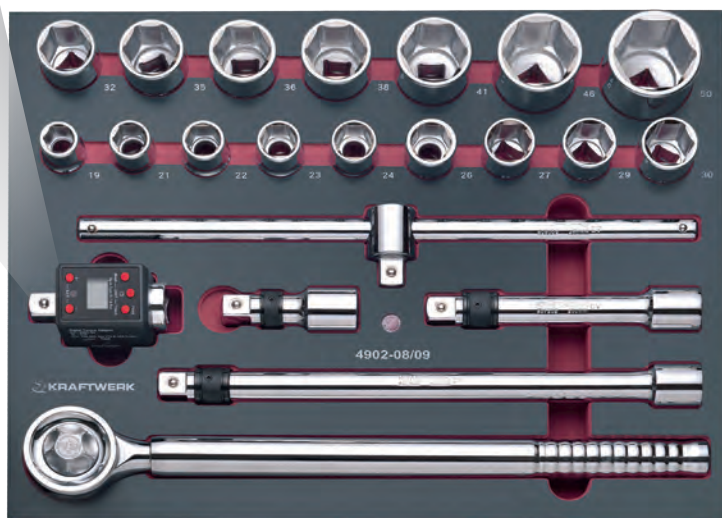

16 19-21-22-23-24-26-27-29-30
32-35-36-38-41-46-50 mm

3 100-200-400 mm

460 mm

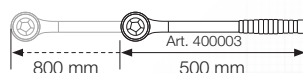

4902-090 / Art. 4081-34

Art. **4081-34**
100-500 Nm (± 2%) / 73.8-369 Lb.ft
kg-m / kg-cm / lb-in / ft-lbs

4902-091 / Art. 4081-341

Art. **4081-341**
200-1000 Nm (± 2%) / 147.6-738 Lb.ft
kg-m / kg-cm / lb-in / ft-lbs

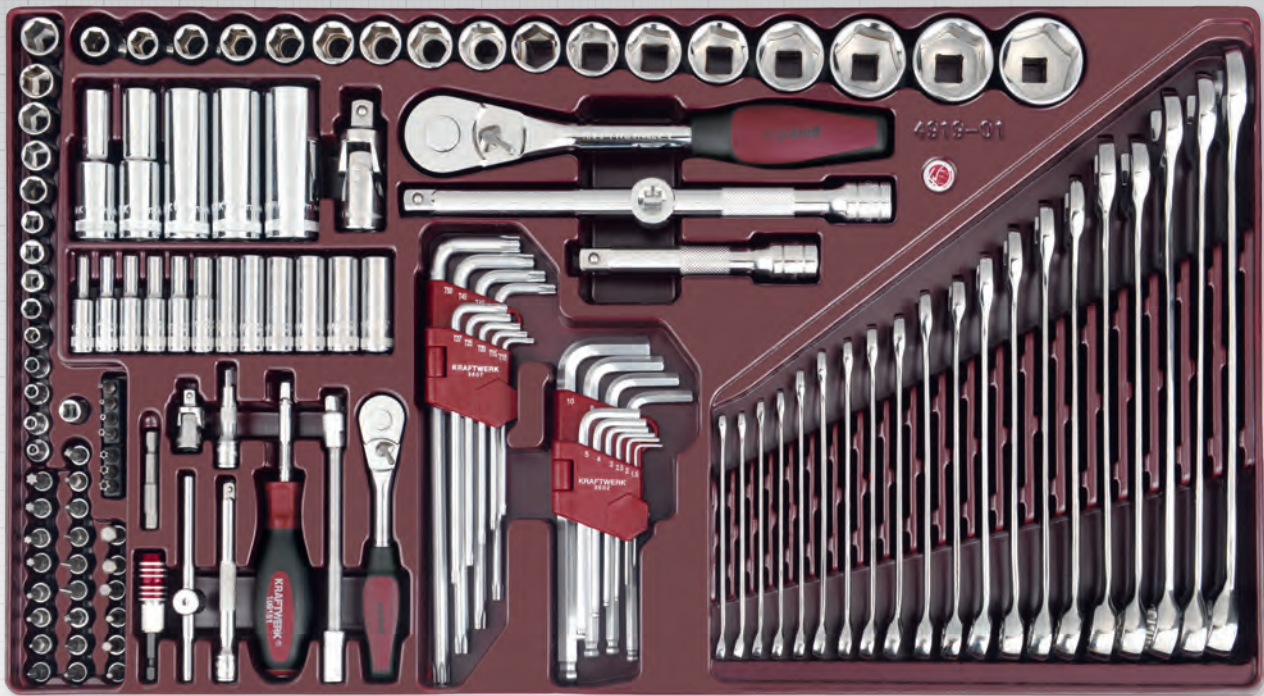

ergokraft

132
PCS

- 14 3.5-4-4.5-5-5.5-6-7-8-9-10-11-12-13-14 mm
- 12 4-4.5-5-5.5-6-7-8-9-10-11-12-13 mm
- 3 4-5.5-6.5 mm
- 3 PH 1-2-3
- 3 PZ 1-2-3
- 8 T8-T10-T15-T20-T25-T27-T30-T40
- 6 3-4-5-6-7-8 mm
- 1/4" 1/4"
- 1/4" 1/4"
- 2 50 mm / 100 mm
- 150 mm
- 115 mm
- 1/4" 1/4"
- 7 T10-T15-T20-T25-T27-T30-T40
- 1/4" 1/4"
- 1/4" 1/4"
- Art. 3200

- 17 10-11-12-13-14-15-16-17-18-19-21-22-24-27-30-32-34 mm
- 5 10-13-17-19-22 mm
- 1/2" 1/2"
- 2 125 mm / 250 mm
- 3/8" 1/2"
- Art. 3220
- Art. 3602
- DIN 2936 S2** 1.5-2-2.5-3-4-5-6-7-8-10 mm
- Art. 3607
- XXL S2** T10-T15-T20-T25-T27-T30-T40-T45-T50

- DIN 3113**
- Art. 3505 5.5 mm
 - Art. 3506 6 mm
 - Art. 3507 7 mm
 - Art. 3508 8 mm
 - Art. 3509 9 mm
 - Art. 3510 10 mm
 - Art. 3511 11 mm
 - Art. 3512 12 mm
 - Art. 3513 13 mm
 - Art. 3514 14 mm
 - Art. 3515 15 mm
 - Art. 3516 16 mm
 - Art. 3517 17 mm
 - Art. 3518 18 mm
 - Art. 3519 19 mm
 - Art. 3520 20 mm
 - Art. 3521 21 mm
 - Art. 3522 22 mm
 - Art. 3523 23 mm
 - Art. 3524 24 mm

160
PCS

NEU
NOUVEAU
NUOVO

Service-Werkstattwagen

bestückt

Servante spéciale d'atelier

équipée

Carrello di servizio

con utensili

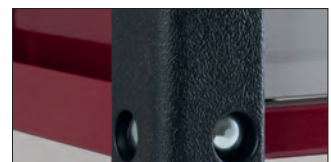
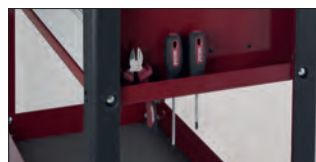











Art.			
3917-4919	3917	3	6

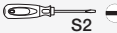
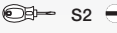
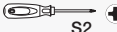
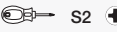

28
PCS

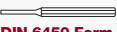
ergokraft

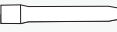
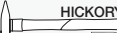

	DIN ISO 5746		DIN ISO 5745
Art. 3281-180 180 mm		Art. 3285-200 200 mm	
	DIN ISO 5749		DIN ISO 5232
Art. 3282-160 160 mm		Art. 3289-160 160 mm	
	DIN ISO 8976		
Art. 3290-250 250 mm			
	S2	Art. 4110-1 0.6 x 3 mm	
		Art. 4110-2 0.8 x 4 mm	
		Art. 4110-3 1.0 x 5 mm	
		Art. 4110-4 1.1 x 6 mm	
		Art. 4110-5 1.2 x 8 mm	
	S2	Art. 4112-2 1.1 x 6 mm	
	S2	Art. 4115-1 PH1	
		Art. 4115-2 PH2	
	S2	Art. 4117-2 PH2	
	GS	Art. 2138 100-250 V	
		Art. 2139 12 V	
		Art. 1350-2 2 mm	
DIN 6450 Form C		Art. 1350-3 3 mm	
		Art. 1350-4 4 mm	
		Art. 1350-5 5 mm	
		Art. 1350-6 6 mm	
		Art. 1350-8 8 mm	
		Art. 1358-2 No. 2	
DIN 7250			
		Art. 3380-18 18 mm	
DIN 6451/53		Art. 3380-22 22 mm	
	HICKORY	Art. 2305 500 g	
DIN 1041	GS		
	HICKORY	Art. 2336 Ø 35 mm	
		Art. 4700-0316 3 m x 16 m	



HIGHTECH

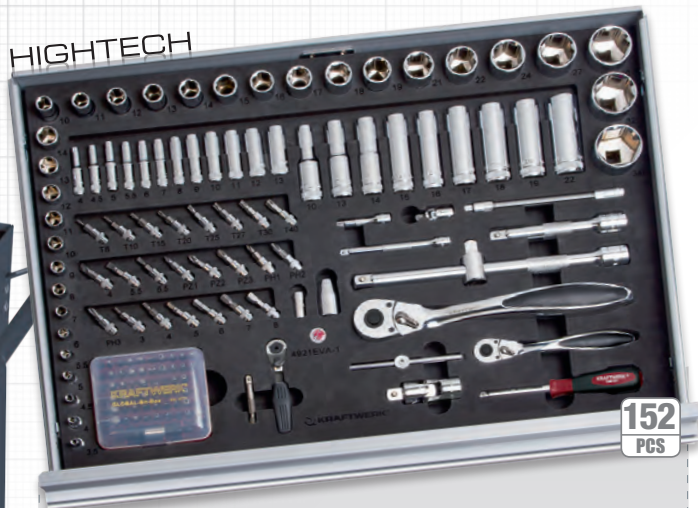

266
PCS

NEU
NOUVEAU
NUOVO

Werkzeugwagen

bestückt, mit Standard-EVA-Einlagen

Servante

équipée, avec mousses EVA standard

Carrello

con assortimento di utensili ed inserti EVA standard

Art.			
1907-4921EVA	1907	7	8



- 14 3.5-4-4.5-5-5.5-6-7-8-9-10-11-12-13-14 mm
- 12 4-4.5-5-5.5-6-7-8-9-10-11-12-13 mm
- 3 4-5.5-6.5 mm
- 3 PH 1-2-3
- 3 PZ 1-2-3
- 8 T8-T10-T15-T20-T25-T27-T30-T40
- 6 3-4-5-6-7-8 mm
- 1/4" 1/4"
- 1/4" 1/4"
- 2 50 mm / 100 mm
- 150 mm
- 105 mm
- 1/4" 1/4"
- 1/4" 1/4"



72 Art. 3799



60 Art. 4000B



17 10-11-12-13-14-15-16-17-18
19-21-22-24-27-30-32-34 mm



9 10-13-14-15-16-17-18-19-22 mm



1/2" 1/2"



2 125 mm / 250 mm



3/8" 1/2"



1/2" 5/16"

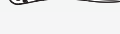

60 Art. 4020B



6 4-4.5-5.5-6-6.5-8 mm

4 PH 1-2-3-4

4 PZ 1-2-3-4

8 T8-T10-T15-T20
T25-T27-T30-T40

8 T8-T10-T15-T20
T25-T27-T30-T40

6 3-4-5-6-7-8 mm

6 2-2.5-3-4-5-6 mm

6 5/64"-3/32"-7/64"-1/8"-9/64"-5/32"

3 Nos. 6-8-10

4 Nos. 1-2-3-4

4 Nos. 4-6-8-10

GLOBALBIT-Box
Art. 3777

61
PCS

101 x 90 x 32 mm



1/4" 1/4" 1/4" 1/4"

ergokraft



44
PCS



DIN 3113

Art. 3505	5,5 mm	Art. 3511	11 mm	Art. 3517	17 mm	Art. 3524	24 mm
Art. 3506	6 mm	Art. 3512	12 mm	Art. 3518	18 mm	Art. 3527	27 mm
Art. 3507	7 mm	Art. 3513	13 mm	Art. 3519	19 mm	Art. 3530	30 mm
Art. 3508	8 mm	Art. 3514	14 mm	Art. 3520	20 mm	Art. 3531	31 mm
Art. 3509	9 mm	Art. 3515	15 mm	Art. 3521	21 mm	Art. 3532	32 mm
Art. 3510	10 mm	Art. 3516	16 mm	Art. 3522	22 mm		



DIN 2936 S2 Art. 3602
1.5-2-2.5-3-4-5-6-7-8-10 mm

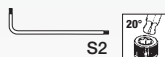

S2 Art. 3608
T10-T15-T20-T25-T27
T30-T40-T45-T50



ergokraft
DIN 3117 / ISO 6787
Art. 3572 150 mm / 6"
Art. 3573 200 mm / 8"

ergokraft



18
PCS



DIN ISO 5746
Art. 3281-180 180 mm



DIN ISO 5749
Art. 3282-130 130 mm
Art. 3282-160 160 mm



DIN ISO 5745
Art. 3285-200 200 mm



DIN ISO 5745
Art. 3286-200 200 mm/45°



DIN ISO 5232
Art. 3289-160 160 mm



Art. 4110-1 0.6 x 3 mm
Art. 4110-2 0.8 x 4 mm
Art. 4110-3 1.0 x 5 mm
Art. 4110-4 1.1 x 6 mm
Art. 4110-5 1.2 x 8 mm
Art. 4110-6 1.6 x 10 mm

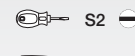

Art. 4112-2 1.1 x 6 mm



Art. 4115-1 PH1
Art. 4115-2 PH2

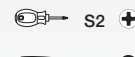

Art. 4117-2 PH2



Art. 4128 1/4"



Art. 2138 100-250 V

ergokraft



22
PCS



DIN 6450 Form C
Art. 1350-2 2 mm
Art. 1350-3 3 mm
Art. 1350-4 4 mm
Art. 1350-5 5 mm
Art. 1350-6 6 mm
Art. 1350-8 8 mm



DIN 6458
Art. 1355-2 2 mm
Art. 1355-3 3 mm
Art. 1355-4 4 mm
Art. 1355-5 5 mm
Art. 1355-6 6 mm



DIN 7250
Art. 1358-1 No. 1
Art. 1358-2 No. 2



DIN 6451/53
Art. 3380-18 18 mm
Art. 3380-22 22 mm

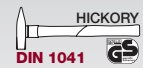

HICKORY
DIN 1041 Art. 2303
300 g

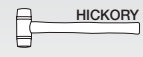

HICKORY Art. 2336
Ø 35 mm



Art. 4320-1 320 mm
DIN 7261



Art. 4320-2 320 mm
DIN 7261



Art. 4320-3 320 mm
DIN 7261



Art. 4320-4 320 mm
DIN 7261



Art. 4320-5 320 mm
DIN 7261

ergokraft



30
PCS



Art. 4321

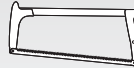

Art. 3305 300 mm



Art. 3308-1



HSS-Bimetall Art. 3316-24 300 mm



Art. 2240



Art. 3310 9 mm



12x Art. 3313 9 mm



Art. 3312 18 mm



5x Art. 3314 18 mm



Art. 5433 3-30 mm CU



Art. 5470 Ø 4-40 cm



200
PCS

- 13 4-4.5-5-5.5-6-7-8-9-10-11-12-13-14 mm
- 6 6-8-10-11-12-13 mm
- \square 1/4" \square 1/4"
- 100 mm
- \square 1/4" \square 1/4"
- \square 1/4" \square 1/4"
- (45) Art. 1000

- 1/4"
- \square 1/4" \square 1/4"
- (1/4")

- (1/2") 16 10-11-12-13-14-15-16-17-18
19-21-22-24-27-30-32 mm
- 2 16 mm / 21 mm
- \square 1/2" \square 1/2"
- 2 125 mm / 250 mm
- \square 3/8" \square 1/2"
- \square 1/2" \square 5/16"
- (45) Art. 1020
- S2 Art. 1110-1 3.2 x 75 mm
Art. 1110-2 4.0 x 100 mm
Art. 1110-3 5.0 x 100 mm
Art. 1110-4 6.0 x 150 mm
Art. 1110-5 8.0 x 150 mm
- S2 Art. 1112-2 6.0 x 38 mm
- S2 + Art. 1115-1 PH1
Art. 1115-2 PH2
- S2 + Art. 1117-2 PH2
- GS Art. 2138 110-250 V

- (5/16") 4 mm
- 4 \square 2-2.5-3-4 mm
- 3 + PH00-2xPH0 Art. 3180
- 2 + PZ00-PZ0
- 6 T6-T7-T8-T9-T10-T15
- 3 1.5-2-2.5 mm
- 3 1.5-2-2.5 mm
- \square 4 mm

286
PCS

NEU
NOUVEAU
NUOVO

Werkzeugwagen
bestückt
Servante
équipée
Carrello
con utensili





Art.			
1097	2907	7	7





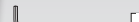

S2
quality

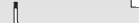
42
PCS

-  20 5.5-6-7-8-9-10-11-12-13-14-15
16-17-18-19-20-21-22-23-24 mm
-   1.5-2-2.5-3-4-5-6-8-10 mm
-  T10-T15-T20-T25-T27-T30-T40-T45-T50

-  Art. 1281-180 180 mm
DIN ISO 5746
-  Art. 1282-160 160 mm
DIN ISO 5749
-  Art. 1285-200 200 mm
DIN ISO 5745
-  Art. 1289-160 160 mm
DIN ISO 5232







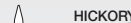

CrV

44
PCS







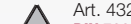

-  Art. 1350-2 2 mm
- DIN 6450 Form C** Art. 1350-3 3 mm
- Art. 1350-4 4 mm
- Art. 1350-5 5 mm
- Art. 1350-6 6 mm
- Art. 1350-8 8 mm

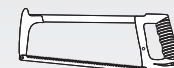
-  Art. 1358-2 No. 2
- DIN 7250**
-  Art. 3380-18 18 mm
- DIN 6451/53** Art. 3380-22 22 mm

-  **HICKORY** Art. 2303
- DIN 1041**  300 g
-  **HICKORY** Art. 2336
- Ø 35 mm

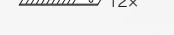
-  Art. 4320-1 320 mm
- DIN 7261**
-  Art. 4320-2 320 mm
- DIN 7261**
-  Art. 4320-3 320 mm
- DIN 7261**
-  Art. 4320-4 320 mm
- DIN 7261**
-  Art. 4320-5 320 mm
- DIN 7261**

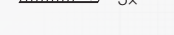
-  Art. 4321

-  Art. 3305 300 mm
-  Art. 3308-1
- ergokraft**
-  Art. 3316-24 300 mm
- HSS-Bimetall**
-  Art. 3310 9 mm
-  12x Art. 3313 9 mm
-  Art. 3312 18 mm
-  5x Art. 3314 18 mm
-  Art. 2240
- ergokraft**



56
PCS

14 6-8-9-10-11-12-13-14
15-16-17-18-19-22 mm

HICKORY Art. 2303 300 g
DIN 1041

HICKORY Art. 2336 Ø 35 mm

Art. 4320-1

Art. 4321

Art. 4996

S2 Art. 1110-1 3.2 x 75 mm
Art. 1110-2 4.0 x 100 mm
Art. 1110-3 5.0 x 100 mm
Art. 1110-4 6.0 x 150 mm
Art. 1110-5 8.0 x 150 mm

S2 Art. 1112-2 6.0 x 38 mm

S2 Art. 1115-1 PH1
Art. 1115-2 PH2

S2 Art. 1117-2 PH2

Art. 2138 100-250 V

4 mm 4 2-2.5-3-4 mm Art. 3180

3 PH00-2xPH0

2 PZ00-PZ0

6 T6-T7-T8-T9-T10-T15

3 1.5-2-2.5 mm

3 1.5-2-2.5 mm

4 mm



95
PCS

Art. 1281-180 180 mm
DIN ISO 5746

Art. 1282-160 160 mm
DIN ISO 5749

Art. 1285-200 200 mm
DIN ISO 5745

Art. 2221-250 250 mm

Art. 2225 240 mm

Art. 1350-2 2 mm
DIN 6450 Form C Art. 1350-3 3 mm
Art. 1350-4 4 mm
Art. 1350-5 5 mm
Art. 1350-6 6 mm
Art. 1350-8 8 mm

Art. 1358-2 2 mm
DIN 6458

Art. 3380-18 18 mm
DIN 6451/53 Art. 3380-22 22 mm

Art. 3305 300 mm

Art. 3310 9 mm

12x Art. 3313 9 mm

Art. 3312 18 mm

15x Art. 3314 18 mm

ergokraft Art. 2240

50
PCS

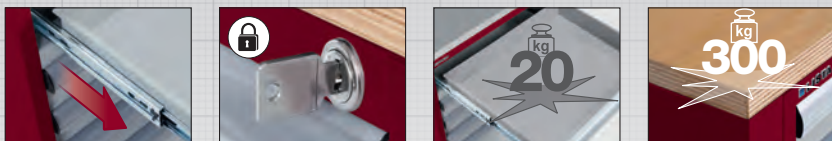

Werkbänke

Schubladenblöcke mit kugelgelagerten Schubladen mit Vollauszug und Zentralverschluss. Tragkraft pro Schublade 20 kg, Total-Belastbarkeit bis 300 kg, ausgerüstet mit 3 cm dicker Multiplexplatte, spritzwasserfest, schmutzabweisend und weitgehend unempfindlich gegen Öl und Fett.



Établis

avec blocs-tiroirs, mécanisme à roulement et ouverture totale, serrure centrale. Charge par tiroir jusqu'à 20 kg, charge totale jusqu'à 300 kg, équipés d'un plateau multiplex 3 cm d'épaisseur, résistant à l'eau, peu salissant et ne craignant pas les tâches d'huile et de graisse.

Banchi da lavoro

con Armadi a cassette con guide su cuscinetti a sfera e l'estrazione totale, chiusura centrale. Possibilità di carico fino a 20 kg a cassetto. Corredato da un ripiano in faggio naturale multiplex spesso 3 cm, capace di sopportare un carico fino a 300 kg, resistente all'acqua e molto duraturo poiché resiste bene allo sporco, all'olio e al grasso.



Werkbank

mit Werkbankjoch und Schubladenschrank

Établi

avec support d'établi et 1 bloc-tiroirs

Banco da lavoro

con sostegno e 1 armadio a cassette

Werkbank

mit 2 Schubladenschränken

Établi

avec 2 blocs-tiroirs

Banco da lavoro

con 2 armadi a cassette

Art.	
7534	6

Art.	
7504	6 + 1

	L1 / mm	L2 / mm	L3 / mm
A	1600	600	900
A	500	500	100

	L1 / mm	L2 / mm	L3 / mm
	2200	800	900
A	500	500	100
B	500	500	500

COMPLETO Serie 4901





Werkzeug-Zusammenstellung
Assortiment d'outils
Assortimento di utensili

Art.	
4921	4901-01B, 4901-03B, 4901-04B, 4901-06B, 4901-07B, 4901-10B, 4901-11B, 4901-13B, 4901-14B

✚ L1 502 x L2 167 x L3 45 mm

Werkbänke
 mit integriertem Werkzeug-Sortiment
Établi
 avec assortiment d'outils intégré
Banco da lavoro
 con assortimento di utensili integrato

Art.			
7534-4921	7534	6	68
7504-4921	7504	6 + 1	68



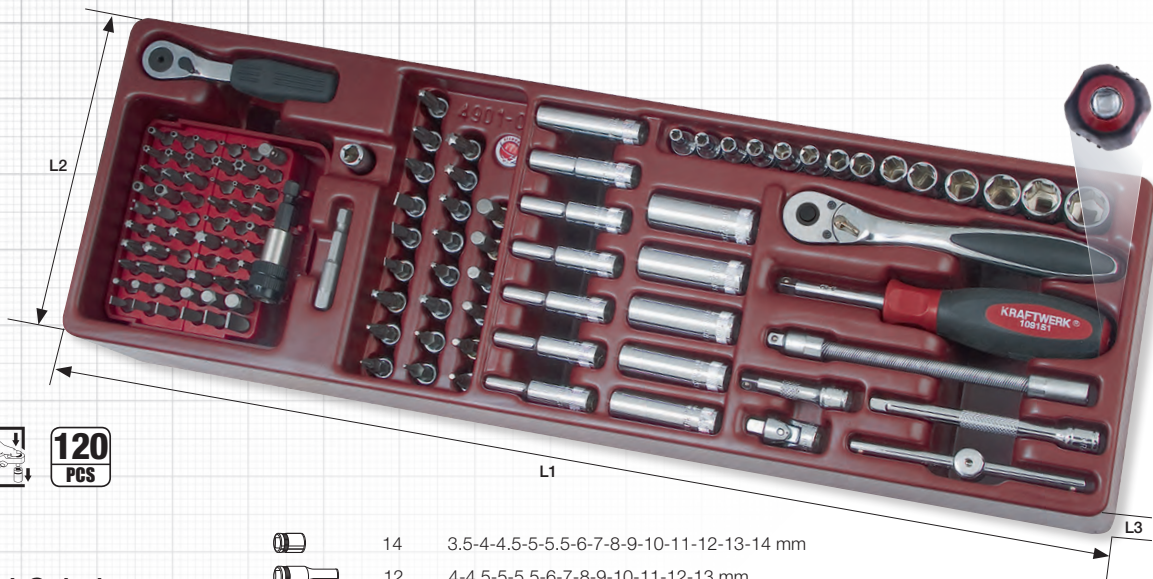

Steckschlüssel-Schale
Coquille de douilles
Assortimento di chiavi a bussola in vaschetta

Art.
4901-01B

↔ L1 502 × L2 167 × L3 45 mm

- 14 3.5-4-4.5-5-5.5-6-7-8-9-10-11-12-13-14 mm
- 12 4-4.5-5-5.5-6-7-8-9-10-11-12-13 mm
- 3 4-5.5-6.5 mm
- 3 PH 1-2-3
- 3 PZ 1-2-3
- 8 T8-T10-T15-T20-T25-T27-T30-T40
- 6 3-4-5-6-7-8 mm
- 1/4" 1/4"
- 1/4" 1/4"
- 2 50 mm / 100 mm
- 150 mm
- 105 mm
- 1/4" 1/4"
- 1/4" 1/4"
- 72 Art. 3799
- 60 Art. 4000B

- 6 4-4.5-5.5-6-6.5-8 mm
- 4 PH 1-2-3-4
- 4 PZ 1-2-3-4
- 8 T8-T10-T15-T20-T25-T27-T30-T40
- 8 T8-T10-T15-T20-T25-T27-T30-T40
- 6 3-4-5-6-7-8 mm
- 6 2-2.5-3-4-5-6 mm
- 6 5/64"-3/32"-7/64"-1/8"-9/64"-5/32"
- 3 Nos. 6-8-10
- 4 Nos. 1-2-3-4
- 4 Nos. 4-6-8-10
- 1/4" 1/4"
- 1/4" 1/4"



Steckschlüssel-Schale
Coquille de douilles
Assortimento di chiavi a bussola in vaschetta

Art.
4901-03B

↔ L1 502 × L2 167 × L3 45 mm

- 17 10-11-12-13-14-15-16-17-18-19-21-22-24-27-30-32-34 mm
- 9 10-11-12-13-14-15-17-19-22 mm
- 1/2" 1/2"
- 2 125 mm / 250 mm
- 3/8" 1/2"
- 1/2" 5/16"
- 60 Art. 4020B



34
PCS

Gabelring-/Inbus-/TX-Winkelstiftschlüssel-Schale

Coquille de clés combinées et de clés mâles hexagonales et TX

Assortimento di chiavi combinate, chiavi maschio, esagonali e TX in vaschetta

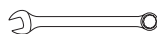

DIN 3113

Art. 3505	5.5 mm	Art. 3513	13 mm
Art. 3506	6 mm	Art. 3514	14 mm
Art. 3507	7 mm	Art. 3515	15 mm
Art. 3508	8 mm	Art. 3516	16 mm
Art. 3509	9 mm	Art. 3517	17 mm
Art. 3510	10 mm	Art. 3518	18 mm
Art. 3511	11 mm	Art. 3519	19 mm
Art. 3512	12 mm		



DIN 2936 S2



●● Art. 3602

1.5-2-2.5-3-4-5-6-7-8-10 mm



XXL S2

●● Art. 3607

T10-T15-T20-T25-T27
T30-T40-T45-T50

Art.

4901-13B

↔ L1 502 × L2 167 × L3 45 mm



ergokraft

10
PCS

Gabelringschlüssel-Schale

Coquille de clés combinées

Assortimento di chiavi combinate in vaschetta



DIN 3113

Art. 3520	20 mm	Art. 3524	24 mm
Art. 3521	21 mm	Art. 3527	27 mm
Art. 3522	22 mm	Art. 3530	30 mm
Art. 3523	23 mm	Art. 3532	32 mm



ergokraft

DIN 3117 / ISO 6787

Art. 3572 150 mm / 6"
Art. 3573 200 mm / 8"

Art.

4901-14B

↔ L1 502 × L2 167 × L3 45 mm

ergokraft



S2
quality



12
PCS

Schraubendreher-Schale
Coquille de tournevis
Assortimento di giraviti
in vaschetta

Art.

4901-04B

↔ L1 502 × L2 167 × L3 45 mm

	S2	Art. 4110-1	0.6 × 3 mm
		Art. 4110-2	0.8 × 4 mm
		Art. 4110-3	1.0 × 5 mm
		Art. 4110-4	1.1 × 6 mm
		Art. 4110-5	1.2 × 8 mm
		Art. 4110-6	1.6 × 10 mm
	S2	Art. 4115-1	PH1
		Art. 4115-2	PH2

	S2	Art. 4112-2	1.1 × 6 mm
	S2	Art. 4117-2	PH2
		Art. 4128	1/4"
	GS	Art. 2138	100-250 V

ergokraft



6
PCS

Zangen-Schale
Coquille de pinces
Assortimento di pinze in
vaschetta

Art.

4901-07B

↔ L1 502 × L2 167 × L3 45 mm

 **DIN ISO 5746**
Art. 3281-180 180 mm

 **DIN ISO 5749**
Art. 3282-140 140 mm
Art. 3282-160 160 mm

 **DIN ISO 5745**
Art. 3285-200 200 mm

 **DIN ISO 5745**
Art. 3286-200 200 mm/45°

 **DIN ISO 5232**
Art. 3289-160 160 mm

ergokraft







12
PCS

Feilen-Schale
Coquille de limes
Assortimento di lime
in vaschetta

Art.

4901-10B

↔ L1 502 × L2 167 × L3 45 mm

-  Art. 4320-1 320 mm
DIN 7261
-  Art. 4320-2 320 mm
DIN 7261
-  Art. 4320-3 320 mm
DIN 7261
-  Art. 4320-4 320 mm
DIN 7261
-  Art. 4320-5 320 mm
DIN 7261

 Art. 4321

 Art. 5470 Ø 4-40 cm



ergokraft





23
PCS



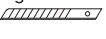

Schneidwerkzeug-Schale
Coquille d'outils de coupe
Assortimento di attrezzi da
taglio in vaschetta

Art.

4901-11B

↔ L1 502 × L2 167 × L3 45 mm

-  ergokraft Art. 3310 9 mm
-  12x Art. 3313 9 mm
-  ergokraft Art. 3312 18 mm
-  5x Art. 3314 18 mm
-  Art. 3305 300 mm

-  ergokraft Art. 3308-1
-  Art. 3316-24 300 mm
HSS-Bimetall
-  Art. 2240
-  ergokraft
-  Art. 5433 3-30 mm CU









17
PCS

Schlagwerkzeug-Schale
Coquille d'outils de frappe
Assortimento di attrezzi a
percussione in vaschetta

Art.

4901-06B

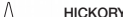
↕ L1 502 × L2 167 × L3 45 mm

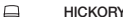
	Art. 1350-2	2 mm
DIN 6450 Form C	Art. 1350-3	3 mm
	Art. 1350-4	4 mm
	Art. 1350-5	5 mm
	Art. 1350-6	6 mm
	Art. 1350-8	8 mm
	Art. 1355-2	2 mm
DIN 6458	Art. 1355-3	3 mm
	Art. 1355-4	4 mm
	Art. 1355-5	5 mm
	Art. 1355-6	6 mm
	Art. 1358-1	No. 1
DIN 7250	Art. 1358-2	No. 2
	Art. 3380-18	18 mm
DIN 6451/53	Art. 3380-22	22 mm
 HICKORY	Art. 2303	300 g
DIN 1041 		
 HICKORY	Art. 2336	Ø 35 mm



Mehrzweck- Etagen-Transportwagen

- 3 grosse Tablare aus Polypropylène/Fiberglas
- sehr stabile Konstruktion mit Aluminiumstangen
- universell einsetzbar
- grosse Lenkrollen Ø 100 mm, davon 2 mit Feststellbremse
- Etagentragfähigkeit: 80 kg
- Wagentragfähigkeit: 160 kg

Chariot de transport à plateau multi-usages

- 3 niveaux de stockage en polypropylène et fibre de verre
- robuste, universel, tiges en aluminium
- roues pivotantes de grand diamètre Ø 100 mm, dont 2 avec frein de blocage
- charge utile par plateau : 80 kg
- charge utile pour l'ensemble : 160 kg

Carrello aperto multiuso

- dotato di 3 grandi ripiani in polipropilene e lana di vetro
- costruzione molto solida per uso universale, aste in alluminio
- 4 ruote girevoli Ø 100 mm, di cui 2 con freno
- portata del ripiano: 80 kg
- portata totale del carrello: 160 kg

Art.	
3912	0

	L1 / mm	L2 / mm	L3 / mm
	900	480	1040
A	660	390	300



COMPLETO Compatible

Mehrzweck-Etagen-Transportwagen

mit kugelgelagerter Schublade

Chariot de transport à plateau multi-usages

avec tiroir, mécanisme à roulement

Carrello aperto multiuso

con cassetto con guide su cuscinetti a sfera

Art.	
3913	1 / Art. 3928

	L1 / mm	L2 / mm	L3 / mm
	900	480	1040
A	570	410	112
B	660	390	190
C	660	390	300



Schublade

kugellagert, zu Mehrzweck-Etagen-Transportwagen 3912

Tiroir

avec mécanisme à roulement
pour chariot de transport multi-usages 3912

Cassetto

con guide su cuscinetti a sfera per carrello 3912

COMPLETO Compatible

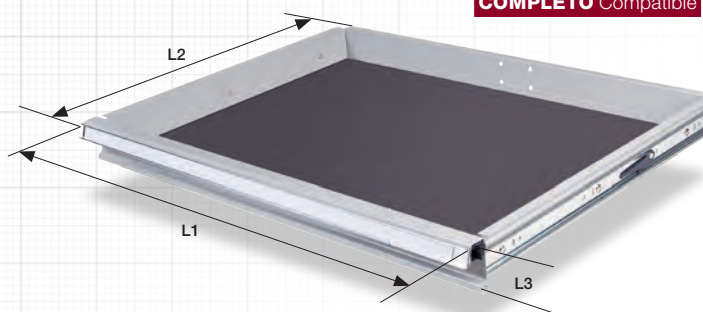

Art.	
3928	1

↔ L1 570 × L2 410 × L3 112 mm



Abfalleimer

für Mehrzweck-Etagen-Transportwagen 3912/3913
aus öl- und säureresistentem Polypropylen

Poubelle

pour chariot de transport à plateau multi-usages
3912/3913 en polypropylène, résistant à l'huile et à l'acide

Pattumiera

per carrello aperto multiuso 3912/3913
in polipropilene, resistente all'olio ed agli acidi

NEU
NOUVEAU
NUOVO

Art.		
3912-99	3912/3913	75

↔ L1 360 × L2 250 × L3 430 mm



19L



Stapelkarre

klappbar

Diable

pliant

Carrello manuale a ruote

pieghevole

Art.

3914

L1 / mm	L2 / mm	L3 / mm	L4 / mm
430	255	max. 995	min. 740

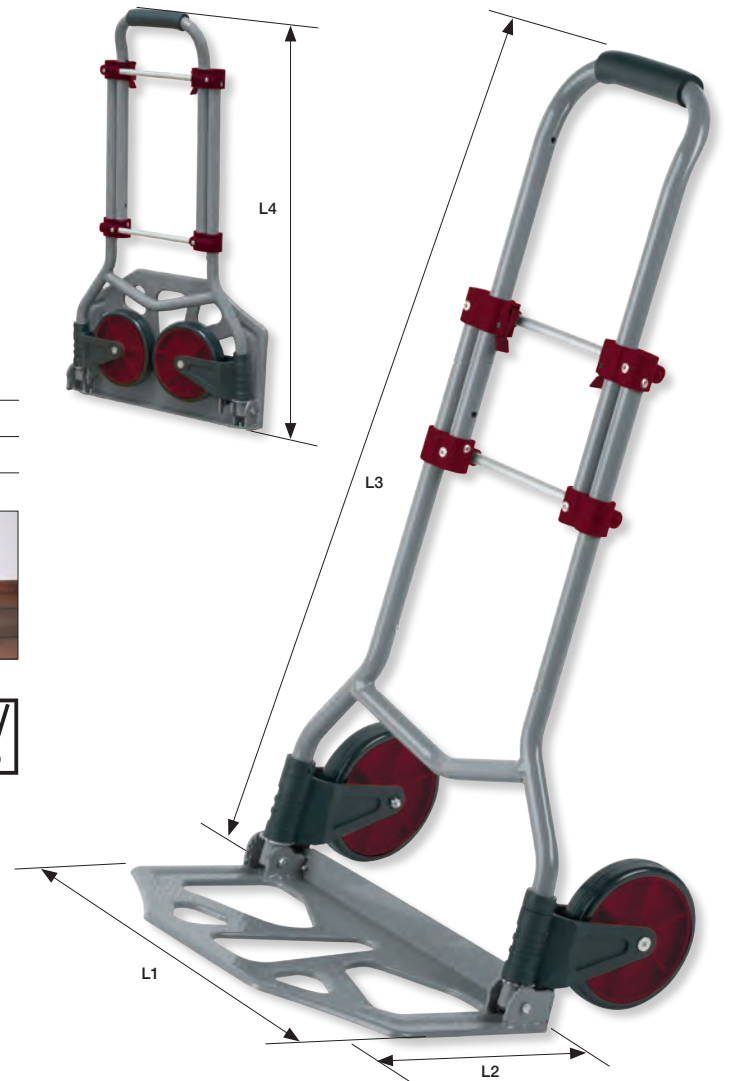

Alu-Arbeitsplattform

Plate-forme de travail en aluminium

Piattaforma di lavoro in alluminio

Art.

3985



Aluminium-Teleskop-Sicherheitsleiter
Echelle télescopique aluminium
Escada telescópica em alumínio

Alu

Art.	kg
3986	11

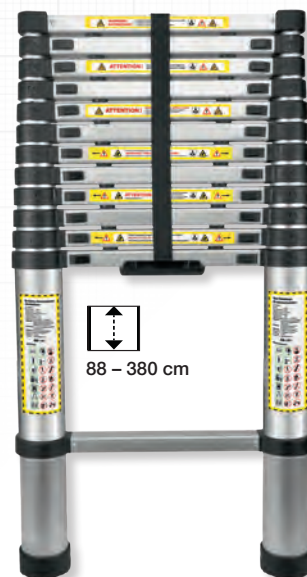
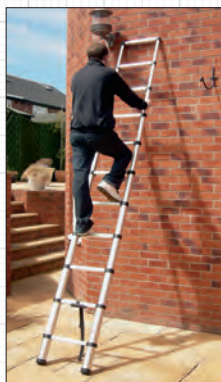
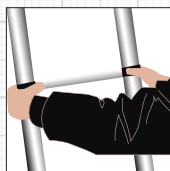

Aluminium-Kombi-Teleskop-
Sicherheitsleiter
*Echelle combinées télescopique
aluminium*
Scala telescópica in alluminio
combinata

Alu **EN131**

Art.	kg
3987	13.8



INDEX / INDICE

Art. No.	Cat.	Art. No.	Cat.	Art. No.	Cat.	Art. No.	Cat.
1096	66/67	3920	9	4900-31B	33	4900-66B	44
1097	64/65	3921	10	4900-33B	40	4900-67B	38
1906	8	3922	10	4900-34B	45	4900E	49
1907	8	3923	12	4900-35B	34	4900K	50
1907-4921EVA	62/63	3924	12	4900-36B	35	4900T	51
1927	14	3925	13	4900-37B	49	4900TS	51
2904	7	3926	16	4900-38B	21	4901-01B	70
2904-4909	17	3927	13	4900-39B	47	4901-03B	70
2904-4911	18	3928	76	4900-39BS	47	4901-04B	72
2905	6	3929	15	4900-40B	25	4901-06B	74
2905-4909	17	3930	16	4900-41B	27	4901-07B	72
2905-4911	18	3985	77	4900-42B	39	4901-10B	73
2907	7	3986	78	4900-43B	39	4901-11B	73
2907-4909	17	3987	78	4900-45B-0391	48	4901-13B	71
2907-4911	18	4900-01B	19	4900-45B-0393	48	4901-14B	71
2907-4917	53	4900-02B	19	4900-45B-0550	48	4902-01	54
2950	14	4900-03B	20	4900-45B-0551	48	4902-02	55
2951	14	4900-04B	31	4900-45B-0553	48	4902-03	55
2952	15	4900-05B	32	4900-45B-0800	48	4902-04	56
3905	4	4900-07B	40	4900-45B-0801	48	4902-05	56
3905-4909	17	4900-08B	42	4900-45B-1200	48	4902-06	57
3905-4911	18	4900-09B	42	4900-46B	26	4902-07	57
3907-1	3	4900-10B	43	4900-47B	26	4902-08	58
3907-4909	17	4900-11B	44	4900-48B	29	4902-080	58
3907-4911	18	4900-12B	45	4900-49B	22	4902-081	58
3908	3	4900-13B	23	4900-50B	30	4902-09	59
3908-4909	17	4900-14B	23	4900-51B	46	4902-090	59
3908-4911	18	4900-15B	28	4900-52B	47	4902-091	59
3908-4917	53	4900-16B	27	4900-53B	47	4909	17
3909	4	4900-17B	24	4900-54B	32	4911	18
3909-4909	17	4900-18B	29	4900-56B	44	4917	52
3909-4911	18	4900-19B	35	4900-57B1	41	4921	69
3909-4917	53	4900-20B	22	4900-57B2	41	7504	68
3910	5	4900-21B	43	4900-57B3	41	7504-4921	69
3912	75	4900-22B	28	4900-58B	21	7534	68
3912-99	76	4900-23B	29	4900-59B	46	7534-4921	69
3913	75	4900-25B	33	4900-60B	31	7721	10
3914	77	4900-26B	34	4900-61B	36	7722	11
3917	6	4900-27B	30	4900-62B	36	7723	11
3917-4919	60/61	4900-28B	25	4900-63B	37	7724	11
3918	9	4900-29B	20	4900-64B	37	7725	12
3919	9	4900-30B	24	4900-65B	38		

KRAFTWERK Partners in Europe



A/S H. Sindby & Co.
Bommerhavevej 41, Sjelde
DK-7100 Vejle
Tel.: +45 75 88 21 22
Fax: +45 75 88 22 40
E-Mail: sindby@sindby.dk
Order: ordre@sindby.dk
Web: www.sindby.dk



PROFIKRAFT TRADING, s.r.o.
Bráfova 6
CZ-Brno 616 00
Tel.: +420 541 249 260
Fax: +420 541 249 261
E-Mail: profikraft@profikraft.cz
Web: www.profikraft.cz



Tecniverca-Máquinas Ferramentas, Lda
Estrada Municipal 1022, nº339
PT-2860-302 Pinhal de Areia-Moita
Tel.: +351 219 584 273
Fax: +351 219 577 133
E-Mail: tecniverca@tecniverca.pt
Web: www.tecniverca.pt



Van Heck - Interpieces N.V.
Havendoklaan 14
BE-1804 Vilvoorde
Tel.: +32 2 255 84 50
Fax: +32 2 255 84 59
Web: www.vhip.be



Harrems Tools B.V.
Labradordreef 6
NL-3565 AN Utrecht
Tel.: +31 30 265 03 21
Fax: +31 30 262 64 24
E-Mail: info@harrems.nl
Web: www.harrems.nl



Techno-Elit & Co. KG
Hatzianesti 6
GR-18233 A.I.Rentis-Athen
Tel.: +30 210 4900064
Fax: +30 210 4900072
E-Mail: info@techno-elit.gr
Web: www.techno-elit.gr



FLESCH EXPORT-IMPORT
Fohlenweg 7
CH-9230 Flawil
Tel. RS: +381 62 587 644
Tel. BiH: +387 65 19 77 39
E-Mail: zivkofleschch@gmail.com
Web: www.flesch-export-import.com



Hosendorfer Ges.m.b.H.
Wodikgasse 7
AT-2353 Guntramsdorf/Wien
Tel.: +43 2236 53491
Fax: +43 2236 52347
E-Mail: office@hosendorfer.at
Web: www.hosendorfer.at



Parts-Center NT
Rruga Tirana p.n.
XK-20000 Prizren
Tel.: +377 44 337 620; 646 920
Fax: +381 29 222 155
E-Mail: n.biri@parts-center.net
Web: www.parts-center.net



INTENSE s.r.l.
Via Novara 1
IT-20063 Cernusco Sul Naviglio (MI)
Tel.: +39 02 921 8151
Fax: +39 02 921 04594
E-Mail: contact@intense.it
Web: www.intense.it



Logey ehf heildverslun
Vesturvör 7
IS-200 Kópavogur
Tel.: +354 511 2055
Fax: +354 511 2056
E-Mail: logey@logey.is
Web: www.logey.is



KRAFTWERK Europe AG
Mettlenbachstrasse 23
CH-8617 Mönchaltorf
Tel.: +41 44 949 40 50
Fax: +41 44 948 11 58
E-Mail: info@kraftwerk.ch
Web: www.kraftwerk.ch



KRAFTWERK Sàrl.
25, rue du Stade
F-67870 Bischoffsheim
Tel.: +33 388 48 64 50
Fax: +33 388 50 27 32
E-Mail: info@kraftwerk.fr
Web: www.kraftwerk.eu



KRAFTWERK Deutschland GmbH
Lebacher Strasse 4
66113 Saarbrücken
Tel.: +49 681 / 99 63 647
Fax: +49 681 / 99 63 646
E-Mail: info@de.kraftwerk.eu
Web: www.kraftwerk.eu



KRAFTWERK IBERICA S.L.
C/De las Vacas, no. 6, oficina 5
ES-28341 Valdemoro (Madrid)
Tel.: +34 91 809 22 97
Fax: +34 91 809 49 33
E-Mail: kraftwerk@futurnet.es
Web: www.kraftwerk.eu

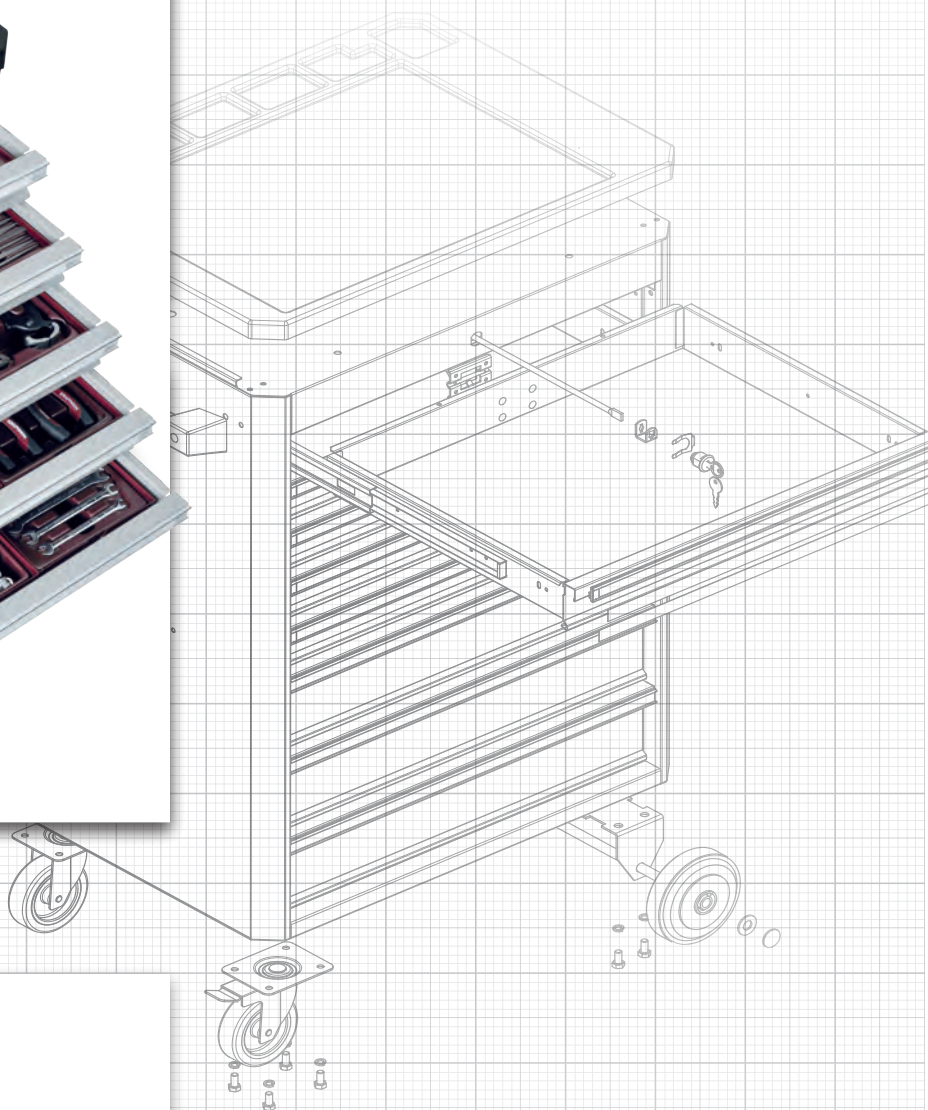

Ihr Fachhändler: | *Votre distributeur spécialisé* : |
Il vostro rivenditore specializzato: